



1955 MODELS

J15 and J11

INSTRUCTION BOOK

**150cc CADET**

**98cc COMET**

*Manufacturers:-*

JAMES MOTOR CYCLES LTD  
GREET, BIRMINGHAM 11

Price: TWO SHILLINGS

# JAMES

**riding and maintenance  
instructions for 1955 models**

**150 cc  
CADET**

MODEL  
J15

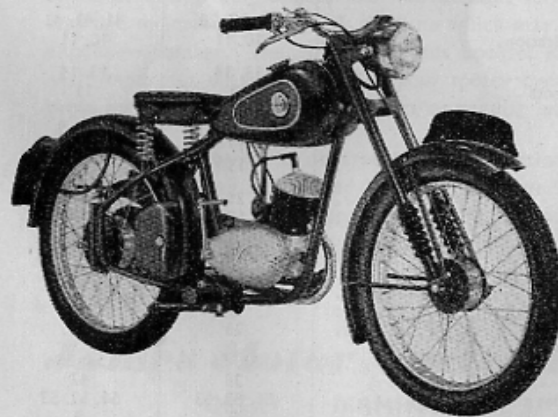
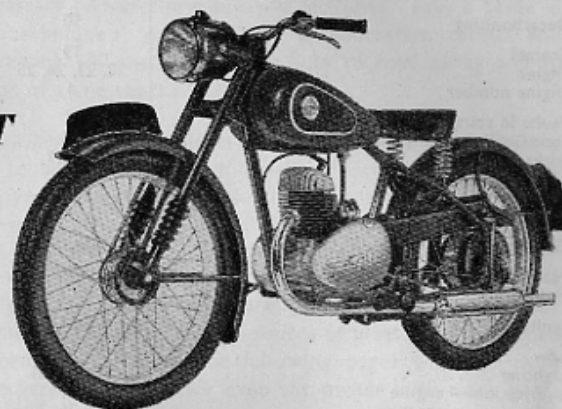

**98 cc  
COMET**

MODEL  
J11

**JAMES MOTOR CYCLES LIMITED  
GREET : BIRMINGHAM, 11 : ENGLAND**

Telephone: VICToria 2211 (5 lines)    Telegrams: MOCYCLE, BIRMINGHAM



## General Information

### FRAME AND ENGINE NUMBERS.

Every James motor cycle is stamped with frame and engine numbers and it is in your interests to record these numbers in the spaces given below. These numbers enable identification of the machine and must be quoted when ordering spares and in any correspondence relating to your motor cycle.

**FRAME NUMBER :** Stamped on the left-hand side of the frame lug under the saddle on both models J15 and J11. Year of manufacture and model number are used as prefixes.

**ENGINE NUMBER :** 150 cc. model J15. On top of aluminium alloy crankcase front engine lug.  
98 cc. model J11. On left-hand side of aluminium alloy crankcase immediately below joint between crankcase and cylinder.

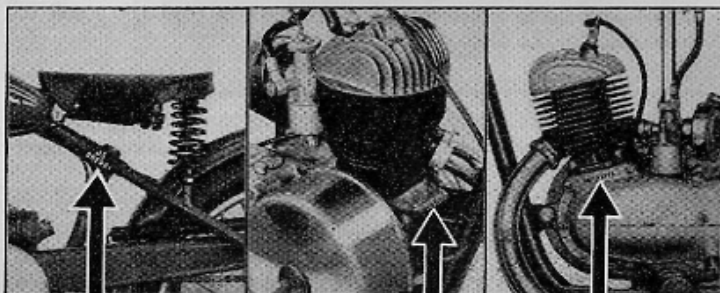

FRAME NUMBER

ENGINE NUMBER—CADET

ENGINE NUMBER—COMET

RECORD YOUR FRAME AND ENGINE NUMBERS HERE FOR REFERENCE

FRAME	ENGINE

### FREE SERVICE SCHEME. (UNITED KINGDOM).

All owners of **NEW MODELS** are entitled to one **FREE SERVICE AND INSPECTION** at 500 miles, or, at latest, three months after taking delivery.

This service is arranged by the supplying dealer to whom the **Free Service Card** must be handed. This voucher will be found in the tool box upon taking delivery of a new motor cycle.

The **INSPECTION AND SERVICE** consists of :

- (a) Check, and, if necessary, adjust :
  - (1) Contact breaker points.
  - (2) Sparking plug.
  - (3) Clutch.
  - (4) Chains.
  - (5) Wheel bearings.
  - (6) Brakes.
  - (7) Forks and rear suspension.
  - (8) Alignment of wheels.
  - (9) Tyre pressures.
- (b) Tighten all external nuts and bolts, including cylinder bolts.
- (c) Check all lighting equipment.
- (d) Clean out carburettor and adjust mixture.
- (e) Adjust and lubricate all cables.
- (f) Grease all nipples.
- (g) Check oil level in primary chaincase.
- (h) Top-up gear box.
- (i) Test machine on the road.

**NOTE :**—Oils, greases and materials used are chargeable to the customer.

### THE MACHINE AND THE LAW. (UNITED KINGDOM).

Every motor cycle used on the public roads of Great Britain must be registered and carry the registration numbers and licence disc allotted to it. The dealer, from whom the machine is bought will generally, attend to all matters legally essential before it is used on the public roads.

#### TO REGISTER A NEW MACHINE

Send the Local Motor Tax Department the following :

- (a) Form "RF1/2," duly completed.
- (b) The certificate of insurance.
- (c) The invoice you received from your dealer when you purchased the machine.
- (d) The appropriate registration fee.

In due course you will receive :

- (1) A Registration Book. (Commonly called the "log" book).
- (2) A Licence Disc.
- (3) Your Insurance Certificate.
- (4) Your Invoice.

The Registration Book and the Licence Disc will bear the registration numbers that have been allotted to your machine and will also show the date the road licence expires. Your number plates must then be painted, in white upon a black background, with the registration numbers in characters of even thickness as follows :

The numbers on the front plate must be  $1\frac{1}{2}$ " high,  $1\frac{1}{4}$ " wide and  $\frac{5}{16}$ " thick with spaces of  $\frac{1}{4}$ " between each two characters.

The numbers on the rear plate must be  $2\frac{1}{2}$ " high,  $1\frac{3}{4}$ " wide and  $\frac{3}{8}$ " thick with spaces  $\frac{1}{2}$ " between each two characters.

The Licence Disc must be enclosed in a watertight container, having a glass front, and this must be fixed to the machine in a conspicuous position, near the front and on the left-hand side.

Although it is not legally necessary to carry your Driving Licence, Insurance Certificate and Registration Book while driving your machine, it should be noted that Police Officers have authority to ask for the Driving Licence and Insurance Certificates at any time.

#### SPEEDOMETER.

A speedometer **MUST** be fitted to all motor cycles over 100 cc. It is supplied as standard equipment on the James Cadet and available as an optional extra for the 98 cc. Comet.

#### LAMPS.

During the official "LIGHTING UP" hours the machine must exhibit a white light facing forwards and a red light facing rearwards. The rear number plate must be adequately illuminated by a white light.

Each electric light bulb **MUST** be marked with its "Wattage." (Beware of cheap, imported bulbs, that do not have this marking.)

All motor cycles made by us have electric equipment that complies with the law regarding position, size of bulbs, marking on bulbs and the correct illumination of the rear number plate.

#### REFLECTOR.

All solo motor cycles **MUST** display a reflector on the rear mudguard as well as a tail light. Reflectors should be  $1\frac{1}{2}$ " in diameter mounted so that the reflecting surface faces squarely to the rear at a height between 15" and 42" from the ground.

## POSITION, FUNCTION AND OPERATION OF CONTROLS.

**FILLER CAP.** On top of fuel tank. Incorporates oil measure for petrol mixture. (4 measures of oil to one gallon of petrol). Screws on and off.

**FUEL TAP.** On left under tank. Pull knob to turn fuel ON. Push in to turn fuel OFF. Always push knob to Off position when stopping for any length of time.

**AIR SHUTTER.** Close to enrich mixture for starting. Use in conjunction with tickler.

**TICKLER.** Small knob on carburettor body. Depress until petrol appears on carburettor body, to provide rich mixture for starting.

**THROTTLE TWIST GRIP.** On right handlebar. Controls speed of engine. Twist towards rider to open. Away from rider to close.

**KICK STARTER.** Vertical lever with folding crank on right of gearbox. Use to start engine.

**CLUTCH LEVER.** Large lever on left handlebar. Pull towards handlebar to release engine drive from rear wheel. Use when moving away from rest and also when changing gear. Always let the clutch in gently to prevent transmission snatch.

**GEAR CHANGE PEDAL.** (150 cc. Cadet) Horizontal lever in front of right hand foot-rest. Move UP to select a lower gear. Move DOWN to select a higher gear. Neutral will be found between First (Bottom) and Second gear.

The pedal will always return to the same position and the foot should be removed from lever between each gear change. Always grip the clutch lever when changing gears.

**GEAR CHANGE LEVER.** (98 cc. Comet) Small lever on right handlebar. Push smartly forward to engage Low gear. Pull towards rider to engage High gear. Neutral will be found between Low and High gears and a ratchet mechanism provides positive location.

**FRONT BRAKE LEVER.** Large lever on right handlebar. Grip to operate front brake. Apply in conjunction with rear brake for maximum braking efficiency.

**REAR BRAKE PEDAL.** To front of left hand side footrest. Press down to operate rear brake.

**LIGHTING SWITCH.** (Direct lighting set—AC equipment). In top of headlamp. Switch has three positions :

L	Pilot and rear lamps lit.
OFF	No lamps in use.
H	Head, rear and speedo lamps lit.

**LIGHTING SWITCH.** (Rectifier/Battery lighting set—AC—DC equipment). In top of headlamp. Switch has 4 positions :

OFF	No lamps in use.
P	Parking lights in use—current supplied by battery.
H	Headlamp, tail light and speedo light in use, current supplied by battery.
DIRECT	Headlamp, tail light and speedo light in use—current supplied from flywheel generator with engine running.

**DIPSWITCH.** On left handlebar. Deflects main headlamp beam downwards and to the left. Prevents dazzling oncoming drivers.

## PREPARING FOR THE ROAD.

### FUEL.

**PETROL MIXTURE.** When the machine first comes into the hands of the rider it will be ready, but for fuel, for the road. Fill the tank with a mixture of ONE part of oil to TWENTY parts of petrol. For convenience a measure is attached to the filler cap (four measures to one gallon). Pour the petrol into the tank first, taking care to push the fuel tap OFF before putting in the oil. Now shake the machine from side to side once or twice to mix the contents of the tank. As the petrol supply is the sole means of lubricating the engine, never neglect to perform this trifling duty.

### STARTING.

See that there is sufficient fuel in the tank.

Ensure gear lever is in NEUTRAL by rolling machine slightly forwards and backwards. (Neutral is between bottom and second gear).

Pull fuel tap to ON position.

Close shutter on air cleaner and depress tickler until fuel appears.

Open twist grip about a quarter of its travel.

Standing over machine, depress kickstarter with a steady swinging movement.

When engine starts do not forget to open the air shutter as fully as possible.

Re-starting when the engine is warm will require no flooding of the carburettor, neither will it be necessary to close the air shutter.

### FAILURE TO START.

If repeated kicks fail to start after flooding (when cold) turn off fuel supply, open throttle wide and clear crankcase of excessive fuel by giving a number of rapid kicks to starter. Keep engine turning over quickly until it fires. Then do not close throttle but keep wide open until engine revolutions have built up and running is normal.

### FAULTS IN STARTING.

Errors often made whilst starting motor cycles are as follows :

Opening throttle too wide : this destroys the advantage of a rich mixture.

Failure to lean the machine slightly to the left, so that pressing of the foot on the kickstarter causes rider and machine to overbalance.

Failure to appreciate that word "kickstarter" is a misnomer. What is really required is a steady swinging movement, the force on the crank being almost constant throughout its travel. A frantic jab does not produce the required spin of the engine.

Tickling the carburettor insufficiently. This operation must produce a head of fuel on the top of the carburettor body.

These faults are easily corrected with care and will result in greatly improved starting.

### RIDING.

**THE FIRST RUN.** Novices are recommended to drive the machine slowly in bottom gear (for short distances only, of course) whilst making themselves familiar with the controls. This is best done by bringing the machine to rest and then restarting by a gradual engagement of the clutch several times. When this can be done without stopping or racing the engine, speed can be increased slightly and a change to the next gear made.

Raise the clutch lever and move the foot or hand control to the required position, after which the clutch lever must be gently released, while the throttle should be opened slightly to take the drive on the higher gear.

The change from a high gear to a lower gear is made in a similar manner. A little practice will probably be necessary in order to change gear with ease and certainty, with all movements correctly synchronised, but the gears are very easy to manipulate and will present little difficulty. The gear change mechanism on a new machine is generally a little stiff and will ease considerably when the machine has been run-in.

### STOPPING.

Before slowing down, glance to the rear to ascertain what vehicles are following and if necessary give the signal "I am going to slow down." (Full details of road signals will be found in The Highway Code available from H.M. Stationery Office).

To stop the machine, close the throttle, apply the brakes and when speed is down to a few miles per hour, raise the clutch. The engine thus assists the brakes in slowing down. Most slowing down, e.g., at traffic lights, can be done by allowing the engine to act as a brake and using the brakes themselves for the last few yards only. When the machine is to be left standing for any length of time, it is advisable to turn off the fuel supply when approaching destination, allowing the engine to use up the supply of fuel in the carburettor whilst coming to rest.

### RIDING IN TRAFFIC.

In slow moving traffic engage lower gears. This permits the engine to run smoothly and enables overtaking to be accomplished in the minimum of time. The engine must never be allowed to labour, and the judicious selection of the right gear will prolong the life of the engine and the transmission system. Slipping the clutch should be avoided. Whenever in doubt about overtaking, always hang back.

### RUNNING-IN.

The manner in which a new motor cycle is driven during the first 1000 miles (1600 kms.) can make or mar its eventual performance and useful life, and owners are therefore strongly advised to exercise great care during the vital "running-in" period. In a new machine, despite the most careful manufacture and assembly, each bearing surface has microscopic idiosyncrasies not entirely suited to the opposite surface and the initial period of "light duties" will give those working parts a mirror finish impossible to achieve by machinery.

Two-stroke engines are quickly run in, owing to their simple and efficient design. However, here, as in everything else, treatment must follow the dictates of common sense, and not too much should be attempted on the first ride. Do not exceed 30 m.p.h. in top gear for the first 100 miles or so and limit your throttle openings to two-thirds in any gear for the first 500 miles.

Sustained high speed should not be indulged in for at least 1,000 miles, when it will probably be time to adjust the contact-breaker point gap. How to do this is shown on pages 27 (150 cc. Cadet) and 42 (98 cc. Comet).

## Riding Hints

One of the most important rules to remember is: Before moving off, pulling out to overtake, turning right and turning left, glance over your shoulder to make sure it is safe to do so and if necessary give the correct signal.

If at first bottom gear will not engage whilst the machine is stationary, do not resort to force—simply raise the clutch and move the machine backwards and forwards for a second or two, then try again. In time this condition will disappear.

Take pride in making a smooth start; it is not clever or wise to race the engine and then let the clutch in suddenly to make a flying start. Make a smooth getaway after first glancing to the rear and signalling your intention.

Always drive on the engine and not on the brakes, thereby saving expense on brake lining. Remember that an engine in low gear is a safe and sure brake and that skidding is well-nigh impossible when using it so.

Change gear on hills **BEFORE** the engine has commenced to labour; a good driver will learn to anticipate such a condition, and change down early.

When changing gear move the foot or hand lever to the full extent of its travel firmly and smoothly, at the same time as the clutch is disengaged.

Cornering. When approaching an uncertain bend at speed, change down if necessary and brake **BEFORE** entering the curve. On a left-hand bend, ease over near the crown of the road in order to sweep in close to the verge once round the corner. On a right-hand bend, always keep well into the verge. Never accelerate into a bend.

When using the brakes, apply gentle pressure at first, increasing in strength as the road speed decreases. Never brake hard unless the machine is vertical.

Use your full headlight when riding at night unless in brightly lit streets.

Make full use of the dipswitch whilst riding at night; this is a "courtesy control" and its use will be appreciated by oncoming drivers.

Always reduce speed when your visibility is lowered.

Many accidents are caused by rash over-taking. Be cautious, remembering that a small engine has not the acceleration of a larger machine. Every car driver has a blind spot in his mirror within which he cannot see you. Make sure that he knows you are there if you are overtaking. Similarly glance behind you before pulling out.

Remember that pedestrians, young or old, are the most likely to make unexpected changes in direction and speed, step off pavements, come from behind stationary vehicles or, in country districts, suddenly appear round the curve of a blind bend. Constant observation and anticipation is required to avoid them.

### TRAINING FOR BEGINNERS.

Skill in motor cycling is not a gift. It has to be learnt and practised. Many clubs operate a scheme in co-operation with the R.A.C. and the A.C.U. for teaching young motor cyclists and beginners to become expert. For details apply to the Motor Cycle Department, Royal Automobile Club, 85 Pall Mall, London, S.W.1.

## Maintenance and Lubrication

Observing the servicing rules painstakingly means trouble free running of your James machine and will preserve its value, while at the same time very little will be needed in the way of replacement parts.

Lubrication and adjustment of cycle and engine parts is of great importance and it is in your interest to carry out these simple jobs in accordance with the routine service plan given below. A list of recommended lubricants is given on the opposite page.

### AFTER THE FIRST 200 MILES (320 kilometres).

Examine the contact breaker points (150 cc. Cadet, see page 27, 98 cc. Comet, see page 42)

Check nuts and bolts for tightness.

Check adjustment of rear chain (see page 20).

Check steering head and front wheel bearings (see page 13 and 15).

### EVERY 500 MILES (800 kilometres).

Inspect oil level in gearbox and primary chaincase. If necessary top up with recommended oil. FILL TO LEVEL PLUGS ONLY.

Oil front fork sliders with oil gun.

### WEEKLY.

Inspect tyres and check pressures (see pages 17, 54 and 56).

Clean sparking plug (see page 18).

### EVERY 1,000 MILES (1600 kilometres).

Check, adjust and oil control cables, levers and twistgrip.

Check adjustment of rear chain. If rollers appear dry, oil with brush. In winter lubricate more frequently. If chain has collected much dirt remove and clean (see page 20).

Grease rear spring units.

Grease speedometer gearbox.

Check adjustment of steering head bearings.

Oil rear brake pedal pivots.

Check front wheel bearings for play. If necessary adjust (see page 15).

Clean and re-oil carburetter air filter.

Clean banjo filter gauze.

Check and adjust sparking plug gap (see page 18).

### EVERY 5,000 MILES (8000 kilometres).

Drain and refill chaincase and gearbox, whilst engine is warm. FILL TO LEVEL PLUGS ONLY, over filling will lead to trouble.

Make thorough examination of lighting cables.

### OCCASIONALLY.

Oil brake cam bearings to ensure smooth application. Oil too such parts as the rear brake lever, cable or rod pivots, and centre stand pivots. The saddle hinge pin should be oiled occasionally and checked to ensure that the saddle is free to pivot without being too tight.

Do **NOT** oil wheel hub bearings. (See page 15 "Hubs and Bearings").

### LUBRICATING YOUR MACHINE.

Oil is the life blood of your motor cycle, and it is essential that your machine be continuously and correctly lubricated in order to secure maximum performance and low running costs. Strict attention and regular use of the recommended lubricants will reduce friction and wear to the minimum.

**ENGINE.** The petrol system of lubrication employed for the two-stroke engine is practically fool proof. A definite proportion of oil is mixed with the petrol in the tank and passed through the carburetter in an atomized form. The recommended ratio is 20 : 1 but under arduous conditions, the ratio can be stepped up to 16 : 1. When the charge is in the crankcase a proportion of oil separates out as a result of heat and the driving action, and remains in the crankcase where it is splashed on to the moving parts by the rotating crankshaft. The remaining oil in the petrol mixture entering the combustion chamber serves to lubricate the piston and cylinder wall. As the amount of fuel used increases with the power output, it will be seen that a greater quantity of oil is supplied under arduous conditions.

**GEARBOX.** The power lost in the transmission is an appreciable percentage of the total power of the engine and only by correct lubrication can the loss be reduced to the minimum. It is impossible to avoid contamination of the lubricating oil with minute particles of metal worn from the gear teeth and operating parts. If these particles are allowed to accumulate in the box, they will accelerate wear of gears and bearings. It is therefore desirable to drain and replenish the gearbox with fresh oil every 5,000 miles. Always drain after a run when the oil is warm and runs out easily. Check the oil level every 500 miles. Overfilling will not improve lubrication and is liable to cause leakage.

**PRIMARY CHAINCASE.** (150 cc. CADET only) The primary chain and clutch run in an oil bath casing and careful maintenance of the oil level will ensure smooth transmission. To check the oil level remove level plug and pour oil through filler plug until it runs out of the lower hole when the machine is vertical. Drain and replenish every 5,000 miles.

**FORKS.** The telescopic fork sliders operate in Tufnol bushes and should be lubricated with an oil gun (not grease) every 500 miles through the four nipples provided.

**HUBS AND STEERING HEAD.** Wheel and steering head bearings are greased when new and require only occasional attention when they should be dismantled, cleaned out with <sup>\*</sup>paraffin and packed with fresh grease.

**CYCLE PARTS.** Although we advise owners to lubricate cycle parts every 1,000 miles, more frequent attention may be desirable during wet weather in order to prevent damage due to rust and to ensure smooth operation of controls. Engine oil is suitable for all cycle parts. Control cables should be lubricated regularly particularly where they emerge from the outer casing as it is here that breakages can occur if the cables are running dry. Other important points are brake cam pivots and the handlebar control levers.

**REAR CHAIN.** If the rollers appear dry, oil with a brush. Periodically it is advisable to wash the chain with <sup>\*</sup>paraffin to remove mud, grit, etc., and to coat with a small amount of recommended grease. Excess of lubrication on the outside of the chain will merely collect dirt and cause rapid wear of the chain and also sprocket teeth. (See also page 20).

<sup>\*</sup> Kerosene

### RECOMMENDED LUBRICANTS.

(U.K. and Overseas).

	SHELL	WAKEFIELD	VACUUM	B.P.	ESSO
ENGINE (All Seasons)	Shell X-100 30	Castrol XL	Mobiloil A	Energol SAE 30	Essolube 30
GEARBOX	Shell Dentax 140	Castrol D	Mobilube C140	Energol SAE 140	Esso Gear Oil 140
CHAIN CASE	Shell Dentax 140	Castrol D	Mobilube C140	Energol SAE 140	Essolube 30
EXPOSED CHAINS AND GREASE NIPPLES	Shell Retinax A or CD	Castrollease Graphited	Mobilgrease No. 2	Energol C 3	Esso Grease
WHEEL HUBS	Shell Retinax A or RB	Castrollease Heavy	Mobil Hub Grease	Energol C 3	Esso Chassis Grease
FORKS and OIL CAN	Shell X-100 30	Castrol XL	Mobiloil A	Energol SAE 30	Esso Bearing Grease
					Essolube 30

ALWAYS USE A BRANDED OIL OF GOOD REPUTE

NOTE :—Model J11 98 cc. Comet has a common chaincase and gearbox filler plug.

## TELESCOPIC FORKS AND HANDLEBAR.

- 1 Hex bolt  $\frac{1}{2}$ " x 26 t.p.i.
- 2 Dished washer.
- 3 Top plate.
- 4 Handlebar with ball joint adjusters.
- 5 Plain washer 1" dia.
- 6 Domed nut, steering stem.
- 7 Adjusting race.
- 8 Ball bearings (21 per race).
- 9 Frame race—upper.
- 10 Frame race—lower.
- 11 Fork crown race.
- 12 Hex nut  $\frac{3}{8}$ " x 26 t.p.i.
- 13 Plain washer  $\frac{3}{8}$ " dia.
- 14 Top spring adaptor.
- 15 Coil spring.
- 16 Slider tube and fork end.
- 17 Bearing bush.
- 18 Oil seal unit.
- 19 Plastic bellow.
- 20 Fork "H" assembly.
- 21 Oil nipple  $\frac{1}{8}$ " B.S.F.

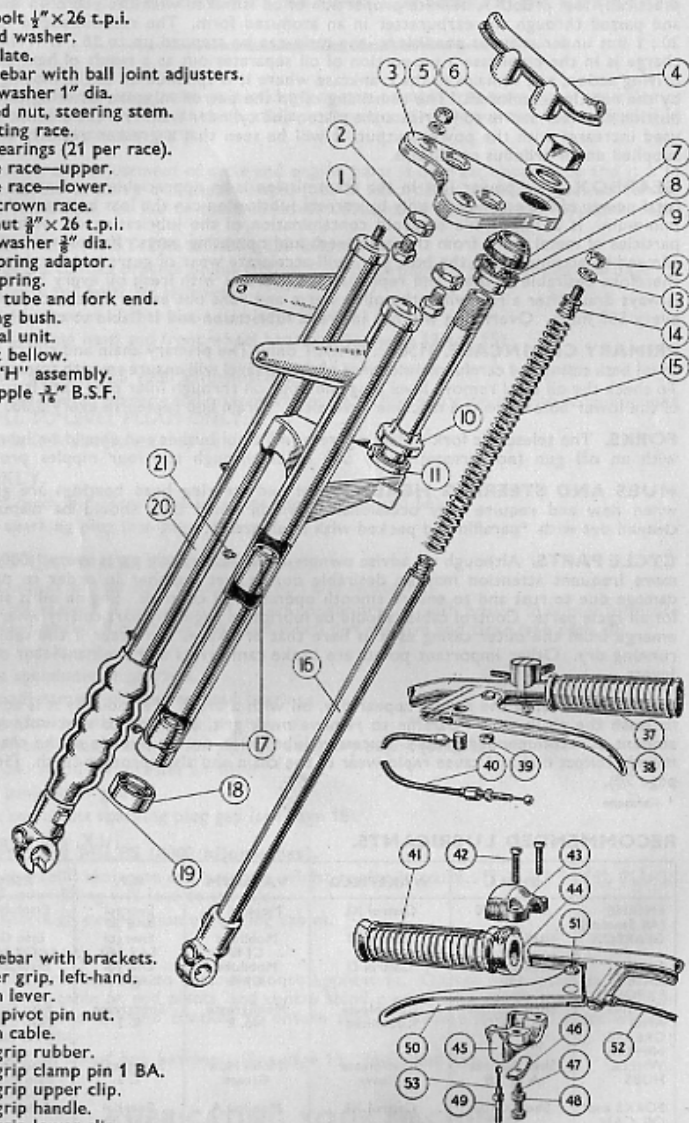

- 36 Handlebar with brackets.
- 37 Rubber grip, left-hand.
- 38 Clutch lever.
- 39 Lever pivot pin nut.
- 40 Clutch cable.
- 41 Twistgrip rubber.
- 42 Twistgrip clamp pin 1 BA.
- 43 Twistgrip upper clip.
- 44 Twistgrip handle.
- 45 Twistgrip lower clip.
- 46 Twistgrip friction spring.
- 47 Twistgrip adjusting pin 1 BA.
- 48 Twistgrip adjusting pin locknut.
- 49 Front brake lever.

- 51 Lever pivot pin.
- 52 Front brake cable complete.
- 53 Throttle cable slotted socket.

## TELESCOPIC FORKS.

Regular lubrication of the sliders is the only attention necessary to keep the forks in first-class working order. The action is by single pressure coil springs secured by screw type adaptors at both ends. The sliders operate in Tufnol bushes pressed into the outer tubes and line reamed after being fitted. For this reason, owners are advised not to interfere with the bushes and since replacements will only be necessary after considerable mileage, it is preferable for the forks to be returned to the local James dealer or to the works for overhaul.

### MAINTENANCE.

Insert oil through the four nipples provided with an oil gun every 500 miles (800 kms.).

### REMOVING SLIDERS.

Place machine on stand and remove front wheel as described on page 15. Take off front mudguard and stays and detach plastic gaiters from outer tubes.

Unscrew hex nuts on top plate above fork members. The sliders can then be withdrawn complete with springs and top plate spring adaptors.

When re-assembling, ensure fork ends are square before locking top nut.

### REMOVING STEERING STEM AND OUTER TUBE ASSEMBLY.

Remove front wheel (see page 15) and fork sliders, detach headlamp and uncouple speedo cable and flex. It is not necessary to disconnect the headlamp wiring, and the handlebar may be left in position on the top plate.

Unscrew head stem domed nut and lift head plate, exposing the adjustable head race. Unscrew the adjusting race, at the same time supporting the steering stem to prevent it from dropping out. There are twenty-one  $\frac{1}{8}$ " ball bearings in each steering stem race. Pack with grease when re-assembling.

N.B. If spring appears to be fouling the outer leg during assembly, slacken top adaptor nut half a turn and rotate adaptor with a screwdriver. This will allow the spring to assume its correct position.

### STEERING STEM ADJUSTMENT.

With the machine on the stand, need for adjustment is indicated when slight movement in the steering stem bearings is felt by trying to rock the forks. Test for slackness at the end of the first 200 miles (320 kms.) and thereafter every 1,000 miles (1600 kms.). The head bearing is adjusted by loosening the domed head stem nut and carefully screwing down the adjusting race under the top plate. **DO NOT ADJUST HEAD BEARINGS TOO TIGHTLY**—this will make steering heavy and may also ruin the bearings.

### HANDLEBAR ADJUSTMENT.

Handlebar angle adjustment is provided by two extensions with hemispherical bases locating in slotted concave recesses in the fork top plate and retained in position by two large hex bolts and dished spacers. To adjust the handlebar position, the two hex bolts under the top plate should be slackened with a plug spanner and the handlebar rotated to the desired position before retightening. On competition models, a wider range of adjustment is provided by clamp pieces and bolts.



## REAR SUSPENSION.

The action is through load and rebound coil springs and regular lubrication is the only attention required for the units to function efficiently for thousands of miles.

### REAR SUSPENSION MAINTENANCE.

Every 1,000 miles (1600 kms.) insert grease through the nipples provided. It is best not to interfere with the units unless absolutely necessary.



## DISMANTLING.

Should it become necessary to dismantle one of the units, proceed as follows :

Place machine on stand and remove rear wheel (see page 15). Detach rear mudguard stays and on left-hand side only, chainguard attachment bolt and silencer.

The top and bottom hex nuts and washers should be removed and both top and bottom knurled caps unscrewed three turns only to ease spring pressure.

Remembering that the rebound spring is still under compression, unscrew the bottom cap, when the spring and spring cover will come out easily.

Next, unscrew top knurled cap, again bearing in mind that the spring is compressed and take out spring and cover.

When the guide rod has been removed, the fork end unit can be manipulated through the aperture in the housing.

The phosphor bronze bushes in the fork end units are line reamed when fitted and if replacements are required, it is advisable to return the unit and guide rod to the local James dealer or to the works for repair.

## RE-ASSEMBLING.

Insert fork-end unit through aperture in plunger housing (N.B. brake side unit has a slot for back plate anchor boss) and fit main spring cover and main spring in top of housing.

Fit bottom knurled cap on guide rod and screw on hex nut three turns only. The recoil spring and cover (short) should be fitted on the guide rod before inserting assembly through bottom of housing and locating the rod through the fork end unit bushes. No attempt to screw the bottom knurled cap into the housing should be made at this stage but the assembly should be held in position.

By pressing the top knurled cap on the main spring, the hex nut may be started on the guide rod, and gradual tightening of both hex nuts will enable the end caps to be screwed into the housing. **GREAT CARE SHOULD BE TAKEN NOT TO CROSS THE SCREW THREADS.** N.B. Bottom cap has a small hole to allow any water to drain away.

Once the caps are fitted into the housing, the whole assembly will be held in position and the hex nuts may be removed to replace mudguard stays, etc. Do not forget to replace the washers under the nuts when rebuilding.

- 1 Guide rod.
- 2 Fork end member, L.H.
- 3 Fork end member, R.H.
- 4 Fork end member, bush.

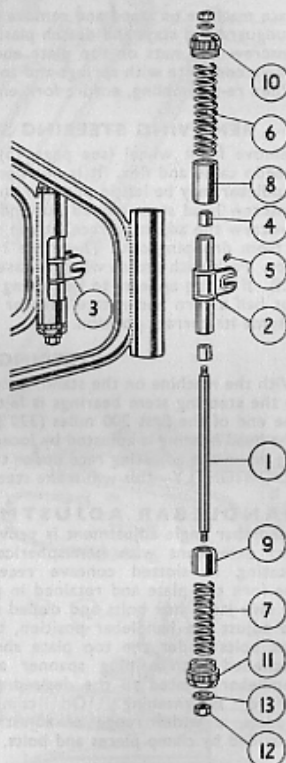

- 5 Grease nipple,  $\frac{1}{4}$ " B.S.F.
- 6 Main spring.
- 7 Recoil spring.
- 8 Cover—main spring.
- 9 Cover—recoil spring.
- 10 Top cap.
- 11 Bottom cap.
- 12 Domed nut  $\frac{3}{8}$ "  $\times$  26 t.p.i.
- 13 Plain washer

## WHEELS.

### FRONT WHEEL REMOVAL.

Place machine on stand and disconnect front brake cable from brake cam lever. Slacken forward facing pinch bolts 2 turns and tap to release cotters. Remove spindle nut from PLAIN side first and then the brake side, after which the wheel will come away easily. When replacing front wheel, tighten both spindle nuts followed by locking the forward facing pinch cotter bolts.

### REAR WHEEL REMOVAL.

Place machine on stand, disconnect chain, taking care not to let it trail on the ground, unscrew brake rod adjuster and speedo drive gland nut. Slacken both spindle nuts. The wheel can then be readily eased out. When replacing, make sure the back plate locking boss is engaged in its groove in the fork end. Remember also that  $\frac{1}{2}$ " whip should be allowed in the rear chain.

It is wise to always check wheel alignment after removal. The simplest way is to use a thin piece of string stretched taut across both wheels with the front wheel pointing straight ahead. The string should just touch each tyre at both sides of the wheel centre. An alternative method is to use a perfectly straight board placed alongside the wheels so that it touches each one. If necessary turn the handlebar so that the front wheel touches the board at two points. If both tyres do not make contact at two points, slacken the rear wheel spindle nuts and turn adjusters until wheel is correctly aligned.

### HUBS AND BEARINGS.

Front hub bearings are of the adjustable cup and cone pattern whereas non-adjustable journal ball bearings are employed in the rear wheel.

Both hubs are greased when new and no further lubrication will be required for several thousand miles, when it is advisable to dismantle the hubs and examine the bearings. The old grease should then be cleaned out with petrol or paraffin and the hubs packed with fresh lubricant when re-assembling. When dismantling the bearings, carefully note the order of assembly shown on page 16. To remove the cups in the front wheel use a long drift pushed through the hub from the opposite end and tap out gently, placing the drift in different places round the cup. If bearings show any sign of wear, fit replacements.

### FRONT WHEEL BEARING ADJUSTMENT.

To adjust front wheel bearings, slacken the nut next to the adjusting cone on the right-hand side and turn the cone clockwise until the wheel rotates freely but has no trace of lateral play.

Great care must be taken to ensure the bearings are not adjusted too tightly. After adjusting the front wheel bearings, make sure the locknut is tightened hard against the adjusting cone. Always use two spanners for the job to prevent the locknut from rotating the adjusting cone when it is tightened. There are ten  $\frac{1}{4}$ " balls each side (20 per wheel).

### SPEEDOMETER DRIVE (Rear Wheel).

A nipple is provided on the speedometer gearbox and a little grease should be inserted by means of a pressure gun every 1,000 miles (1600 kms.). If the speedometer drive has been removed for any reason, do not forget to replace the distance piece behind it.

If the engaging projections on the speedo drive are tight in the locations on the hub, the speedo drive will be damaged.

The speedometer head does not require any lubrication and should never be interfered with.

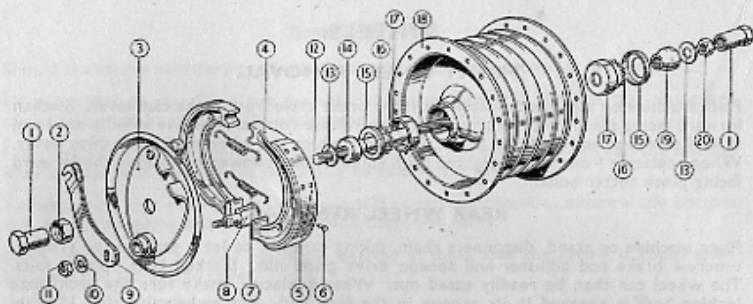

- |   |   |                                   |
|---|---|-----------------------------------|
| 1 Spindle nut $\frac{1}{8}$ " x 26.                   | 8 Brake cam.                                | 14 Fixed cone.                    |
| 2 Recossed nut $\frac{1}{8}$ " x 26 x $\frac{1}{4}$ " | 9 Brake cam lever.                          | 15 Dust cap.                      |
| 3 Brake backplate.                                    | 10 Brake cam special washer.                | 16 Ball bearings $\frac{1}{8}$ ". |
| 4 Brake shoe.   | 11 Hex nut $\frac{1}{8}$ " x 26.            | 17 Bearing cup.                   |
| 5 Brake lining.                                       | 12 Spindle.                                 | 18 Hub shell and brake drum.      |
| 6 Brake rivet.  | 13 Plain washer $\frac{1}{8}$ " x 16 s.w.g. | 19 Adjusting cone.                |
| 7 Brake return spring.                                | 13 Lock washer-adjusting cone.              | 20 Hex locknut.                   |

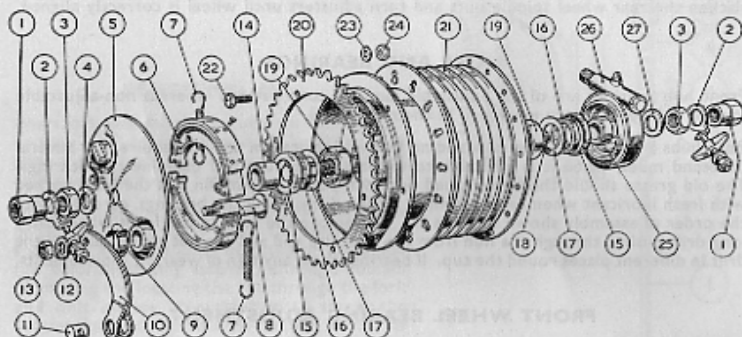

- |   |  |   |
|---|--|---|
| 1 Spindle nut $\frac{1}{8}$ " x 26.               | 10 Brake cam lever.                      | 20 Chain sprocket.                                      |
| 2 Wheel adjusters.                                | 11 Brake cam lever roller.               | 21 Hub shell and brake drum.                            |
| 3 Locknut $\frac{1}{8}$ " x 26 x $\frac{1}{4}$ ". | 12 Plain washer.                         | 22 Hex bolt $\frac{1}{8}$ " x 26.                       |
| 4 Plain washer $\frac{1}{8}$ " x 16 s.w.g.        | 13 Hex nut.                              | 23 Shakeproof washer.                                   |
| 5 Brake backplate.                                | 14 Distance piece $\frac{1}{2}$ " long.  | 24 Hex nut.   |
| 6 Brake shoe complete with lining.                | 15 Dust cap.                             | 25 Distance piece $\frac{1}{2}$ " long.                 |
| 7 Brake lining.                                   | 16 Felt seal.                            | 26 Speedometer drive gearbox (J15).                     |
| 8 Brake lining rivets.                            | 17 Shim washer.                          | 27 Plain washer $\frac{1}{8}$ " x 10 s.w.g. (J11 only). |
| 9 Brake return springs.                           | 18 Spindle.                              |   |
| 10 Oiler spring clip.                             | 19 Journal ball bearing 42 x 15 x 13 mm. |   |

### BRAKES.

If the brakes are correctly adjusted and oil is never used to lubricate the bearings, the brakes will require no attention for many thousands of miles.

Brake cable or rod adjustment should be such that only a slight movement of the lever or pedal is sufficient to operate the brake, but at the same time the wheel must spin freely when the brakes are off. To give the correct adjustment, screw up the adjuster until the liners are just fouling the drum, then slack off two complete turns.

After altering the tension of the rear chain, check the adjustment of the brake rod.

If a small quantity of oil gets onto the linings, this can be removed by soaking in or brushing with carbon-tetra-chloride. If however the linings are oil-saturated, they must be replaced.

### TYRES.

To obtain the maximum mileage from the tyres, maintenance should be regular and painstaking. A good quality tyre pressure gauge is a sound investment and its frequent use will ensure maximum tyre life. Once a week check the tyre pressures with a gauge and at the same time examine the outer covers to ensure no particles of gravel, etc., are wedged in the tread.

RECOMMENDED TYRE PRESSURES : J15 Cadet Front 15 lbs. Rear 22 lbs.  
J11 Comet Front 19 lbs. Rear 29 lbs.

The pressure required naturally varies according to the weight carried by the tyre and the total weight is unevenly distributed between two tyres. To ascertain the correct pressures proceed as follows :

Position the motor cycle on a platform-type weighing machine (one that is level with the ground) with the front wheel only on the platform. Have someone to steady the motor cycle from the rear and sit in the saddle with the feet on the rests. Record the weight and proceed in the same way for the rear tyre. If required, take further readings with pillion passenger. Refer to the table below :

Size of Tyres : 2.25" x 19" and 2.75" x 19".

Load per tyre (lbs.)	..	140	150	162	172	180	192	200	210	220	228	235
Pressure (lbs. per sq. in.)	..	16	17	18	19	20	21	22	23	24	25	26

Example : Your front tyre carries a load of 140 lbs. and the rear 192 lbs. Correct pressures are : front 16 lbs., rear 21 lbs. These pressures are suitable for the average rider weighing between ten and twelve stones.

The following hints will also assist in prolonging the life of the tyres :

Clean oil and grease from the tyres with petrol as soon as possible.

Ensure correct alignment of the wheels.

Cross tramlines at as near a right-angle as possible. They are dangerous, particularly in wet weather and may damage the tread.

Fierce braking and acceleration quickly wear away the tread. Apply brakes gently to avoid skidding, and when starting from rest, accelerate steadily on a small throttle opening.

### TYRE REMOVAL.

Deflate tyre by removing cap and nut from valve stem, and unscrewing inner valve. A small key for this purpose is found on the top of the valve cap.

Push outer cover right into wheel rim well opposite valve, and insert tyre lever under cover as near the valve as possible. If the opposite side is properly in the well the edge of the cover should come over the rim without using force.

Work around cover until all of it is over the rim, then remove inner-tube by pushing valve up through hole and gently easing out. Remove opposite side of cover in the same way—pushing into well, inserting lever in other side and working off.

### TYRE REPLACEMENT.

It is seldom necessary to remove the outer cover completely with normal punctures, but if the tyre has been taken off proceed as follows : Work one side of tyre over rim, insert inner-tube and pump up sufficiently to remove any kinks ; place valve in hole and screw the securing nut about  $\frac{1}{2}$ " up the shaft. The white spot on the side of outer-cover should be positioned over valve.

Move free edge of cover over rim opposite valve and work round rim, equally on either side of valve until a few inches remain free. The valve should be in the centre of this free length and no difficulty should be experienced in getting it over the edge of rim providing the rest of the cover is right down in the well.

Once tyre is home, inflate to about half pressure and manipulate cover until tread runs evenly ; when rotation of the wheel has shown this to be so, inflate to correct pressure. Do not forget to replace the valve cap. This prevents the ingress of dirt.

When fitting new tyres it is a good plan to smear a little soft soap around the rim to ease the cover on.

## SILENCER.

The James silencer provides for a clear passage of the exhaust gases and permits the utmost power output from the engine. No attention should be necessary for several thousand miles but it is advisable to clean it when decarbonising the engine.

To remove for cleaning, release bolt from collar retaining silencer to exhaust pipe and bottom bolt on rear suspension unit. The silencer can then be taken off the machine and after unscrewing the three self-tapping screws, the tail pipe and baffle assembly may be withdrawn.

## SPARKING PLUG.

A Lodge H14 (14 m.m. short reach) plug is fitted as original equipment. This plug will stand up to the maximum power output of the engine without pre-ignition and if the carburettor mixture is correct, little trouble should be experienced. The point gap should be checked every 2,000 miles and reset to .018"-.025" if necessary.

It is a good plan to carry a spare plug of the correct type so that when the plug in use requires cleaning, it can be removed and the clean spare inserted in its place. Keep the spare plug well wrapped up, to protect the all-important points.

### CLEANING THE PLUG.

Grip body very gently in a vice and remove gland nut to free the insulator. Wash in petrol, scraping insulator with a knife or rubbing with fine emery to remove carbon, and wash again. The body can be cleaned internally by scraping and wiped with a petrol-soaked rag. The electrodes should be very carefully scraped. DO NOT rub a wire brush over the points—this will have a ruinous effect. When re-assembling tighten gland nut as much as possible.

Set point gaps to .018"-.025" by tapping OUTSIDE electrodes—NEVER tap the central electrode.

Do not overtighten the plug in the cylinder head; this may result in stripped threads and flattening of the copper washer. A whitish deposit on the insulator denotes a weak carburettor mixture.

### BRIDGING OF PLUG GAP.

This occurs in the form of a deposit between the central electrode and earth points, causing a short circuit and preventing a spark. It is sometimes mistaken for oiling-up but the cause is believed to be the residue of detergent in varying percentages in the lubricating oil. The high working temperature of a two-stroke engine appears to be the reason for this bridging and it follows that a weak mixture, retarded ignition, a choked exhaust system or anything likely to increase the working temperature may result in bridging. Attention to the following will result in an increased mileage before it becomes necessary to clear the points.

- Ensure ignition timing is correct and contact breaker gap is between .014"-.016".
- The carburettor may be set to give a richer mixture.
- The normal spark plug gap should be increased as much as possible consistent with easy starting and good running.

Poor condition of the contact breaker points and connections may also lead to failure.

TO ENSURE BEST PERFORMANCE AND MINIMUM TROUBLE, ALWAYS FIT THE SPARKING PLUG RECOMMENDED BY THE MANUFACTURERS

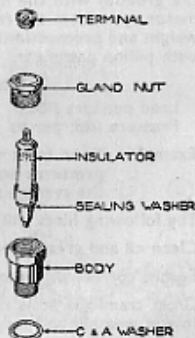

## LUBRICATION OF CONTROLS.

All controls should be adequately lubricated to ensure complete control of the machine at all times. These include levers, cables, brake connections. Small lengths of cable that are exposed should be smeared with grease.

Avoid excessive use of oil on the control levers, as the oil is likely to run along the lever and make them slippery and unpleasant to operate.

## TWIST GRIP ADJUSTMENT.

Adjustment of the spring tension on the twist-grip sleeve is effected by means of a screw and locknut in the bottom half of the twist-grip casting. To increase tension turn the screw clockwise and tighten locknut.

The twist-grip should not be adjusted so that it is difficult to turn as this will probably result in an aching wrist. Adjustment should be such that the grip is easy to operate but remains in position when the hand is removed for signalling, etc.

## SADDLE AND STAND.

It should be noted that the right-hand side of the saddle nose frame is threaded to enable the bolt to act as a pivot for the saddle.

When adjusting, leave sufficient play for the saddle to pivot freely, making for comfortable riding. Oil the hinge pin from time to time.

Centre stand pivots should be lubricated occasionally.

## CLEANING.

Make a practice of giving the machine a really good clean as often as possible. By careful cleaning the original sheen of enamelled parts may be retained indefinitely.

Where mud is thickly caked on, do not attempt to brush it off; abrasive particles will rapidly damage the enamel. Water from a small hose or a wet sponge should be used, taking care not to let water into the carburettor, magneto and brake linings.

Salt laid down in city streets during snowy winter periods has a corrosive effect on enamel and chromium plating. A useful tip is to smear the wheel rims and other exposed parts of the machine with a film of oil or grease. This can easily be removed with a petrol-soaked rag when the weather improves.

James "Touch up" units incorporating a retractable nylon brush and a quantity of James maroon quick drying enamel may be purchased from any James Spares Stockist and will be found useful for retouching small scratches where the paintwork has been damaged.

## CHROMIUM PLATING.

In damp weather, small spots of rust-like deposit may be observed on chromium plating. It is not rust but the action of certain salts used in the plating process. If attended to in good time such spots can easily be removed by rubbing with a good brand of chromium polish. NEVER USE HOUSEHOLD METAL POLISH ON CHROMIUM PLATING.

In summer, when wet conditions are less frequent, it is best to clean plating with a damp chamois leather cloth and soft rag.

### CLEANING—ALUMINIUM ALLOY CASTINGS.

A certain amount of road dirt and oil will inevitably gather on the cast alloy surfaces of the engine crankcase, primary chaincase, gearbox and carburetter, and regular cleaning will not only improve the appearance of the machine but will avoid dirt stains on trouser legs and shoes. A clean engine unit is also easier and more pleasant to maintain.

Such parts can be cleaned with a stiff brush dipped in petrol or, alternately, we recommend a special detergent available from most motor cycle accessory retailers, i.e., GUNK. This product is simply brushed on to the alloy parts and hosed off with water. Gunk is sold in tins and full instructions are given by the makers.

If this method of cleaning is employed care should be taken to cover the carburetter to prevent the entry of water and consequent starting difficulties. Surplus water should always be wiped off with a clean rag.

### CHAINS.

A chain is an assembly of links with rollers connected together by outer link plates and held together by rivets. If it is kept clean, adequately lubricated and correctly adjusted a chain will give little trouble and will wear out long before breaking point is reached.

The front chain is fully enclosed in an oil bath and consequently wear will be negligible over a long period. The rear chain, being exposed and more heavily loaded is more likely to give trouble through neglect and should be regularly checked for tension and frequently lubricated.

#### ADJUSTMENT OF REAR CHAIN.

The rear chain will probably require adjusting after completion of the first 200 miles (320 kms.) owing to stretch which occurs with all new chains. To take up the play, loosen both rear spindle nuts. The adjusters must be rotated the same number of turns in the same direction to keep the wheel in alignment, until there is approximately  $\frac{3}{8}$ " to  $\frac{1}{2}$ " up and down movement in the bottom run of the chain. Check adjustment in various positions by rotating the wheel a little. This is necessary because there is always one spot tighter than the rest. After adjusting, do not forget to tighten the spindle nuts. Re-adjust knurled nut on the brake rod to obtain the correct tension.

Never drive with the chain too tight—this will ruin the gearbox main bearing very rapidly.

#### CLEANING AND LUBRICATING THE CHAIN.

A chain cannot be cleaned merely by drenching with oil while in position on the machine.

The best way to do the job is as follows :

Remove spring clip and connecting link and take chain off the sprockets. Soak in a bath of \*paraffin using a stiff brush to remove all external dirt and allow \*paraffin to run through the joints of the chain. All grit and dirt between the joints must be removed. Swill in clean \*paraffin and hang over a pan to allow it to drain.

Immerse chain in tin containing graphited grease that has been heated until fluid over a pan of boiling water. Move the chain about in the grease until the grease has cooled off to normal semi-solid state. Remove chain from grease and wipe off surplus.

NOTE :—When replacing chain, see that the spring clip faces in direction of drive, i.e., closed end of link should face forwards on top run of chain.

#### SHORTENING REAR CHAIN.

If chain has an even number of pitches, that is, a cranked link is not used in the chain, remove the rivets holding the second pair of outer link plates (see A) which will shorten the chain by four rollers and two pairs of outer link plates. Replace with a cranked double link and single connecting link (B).



\* Kerosene

If chain has an odd number of pitches, remove rivets holding the second pair of outer links see (A) (first pair will be cranked) and replace with single connecting link and inner link (B).

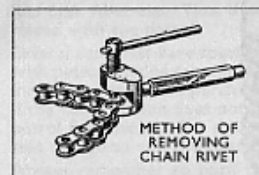
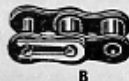

METHOD OF REMOVING CHAIN RIVET

#### CHAIN COMPONENTS

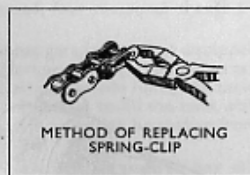

METHOD OF REPLACING SPRING-CLIP



CRANKED DOUBLE LINK



CONNECTING LINK



INNER LINK

#### FITTING A NEW REAR CHAIN.

To simplify the task of fitting a new rear chain, disconnect the old chain at the rear wheel sprocket by removing the single connecting spring link. Connect old chain to new chain, when by pulling the bottom run of the old chain, the new one can easily be carried round the gearbox sprocket, whereupon the old chain is disconnected and the ends of the new one connected together. Care should be taken when fitting a new chain to keep it from contact with the floor or any place where it is likely to collect grit, etc.

#### REPLACEMENT CHAINS.

After considerable mileage, chains will require replacing owing to wear and stretch. These can be purchased either from your James dealer or from the factory.

##### Model J15 150 cc. Cadet.

Primary chain : Renold No. 110038, 64 links,  $\frac{3}{8}$ " pitch,  $\frac{1}{4}$ " roller, .225" wide, pre-stretched.

Rear chain : Renold No. 110044, 116 links,  $\frac{1}{2}$ " pitch, .335" roller, .205" wide.

##### Model J11 98 cc. Comet.

Primary chain : Renold No. 110037, 56 links,  $\frac{3}{8}$ " pitch,  $\frac{1}{4}$ " roller, .225" wide, pre-stretched.

Rear chain : Renold No. 112045, 118 links,  $\frac{1}{2}$ " pitch, .305" roller, .192" wide.

## MODEL J15 147 cc. CADET — POWER UNIT.

Villiers Mark 30C Engine Gearbox Unit.

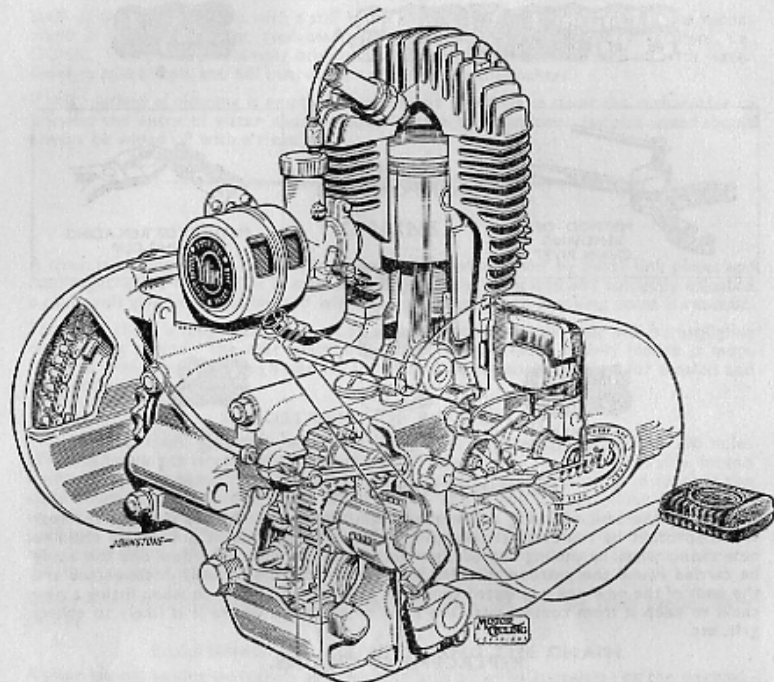

*Drawing reproduced by kind permission of "Motor Cycling"*

The Villiers Mark 30C two-stroke engine fitted to the James Cadet is a highly efficient power unit which, provided it is thoughtfully maintained and lubricated, will give years of service without requiring any major replacements. By virtue of its simplicity, it is cheap and easy to maintain and even owners with no previous motor cycling experience can confidently tackle normal adjustments, maintenance and minor repairs. In the case of major repairs, should they ever arise, we strongly advise the amateur mechanic to entrust the job to a qualified motor cycle repairer or ourselves.

### DESCRIPTION.

In the cylinder walls are arranged four holes or ports, viz. : one inlet port which permits the air fuel mixture to enter the crankcase, two transfer ports which, through passages in the sides of the cylinder, are in communication with the crankcase, and one exhaust port through which the burned charge is allowed to escape. Movement of the piston in a vertical direction is arranged to cover and uncover the ports at suitable times so that the mixture is first drawn from the carburettor through the inlet port into the crankcase. There it is compressed and then forced through the transfer passage into the cylinder above the piston, where it is further compressed. It is then ignited by a spark from the plug, and after expansion due to heat, escapes through the exhaust port into the exhaust pipe and silencer.

### LUBRICATION OF ENGINE.

In order to maintain the efficiency of the engine and to reduce wear to a minimum it is essential that all moving parts are adequately lubricated. The system adopted for Villiers two-stroke engines is the PETROIL system in which a given quantity of oil is mixed with the petrol. As the mixture first enters the crankcase and then into the cylinder, all working parts are adequately lubricated, and as the amount of fuel used will increase with the power output, it will be seen that a greater quantity of oil is supplied under arduous conditions.

The recommended petrol-oil ratio for both 150 cc. and 98 cc. James machines is twenty parts of petrol to one part of oil. For practical purposes, an oil measure is fitted to the fuel tank filler cap. Thus if one gallon of petrol is purchased, four measures should be mixed with the petrol.

Several countries have special petrol mixing pumps, and most garages are now equipped with petrol mixing cans for two-stroke motor cycles. Owners are strongly advised to ask for this service when purchasing petrol to ensure positive mixing before filling the tank. If the filling station does not offer a petrol mixing service, it is best to fill the tank with petrol first and to pour the oil in afterwards. The machine should then be shaken from side to side to mix the contents of the tank.

Always remember to push the fuel tap to OFF before refuelling. It pays to buy oils of good repute and the following brands are recommended as providing first-class lubrication when mixed with petrol: Shell X-100, Wakefield Castrol XL, Vacuum Mobiloil A, BP Energol SAE 30 and Essolube 30.

### ENGINE MAINTENANCE.

Periodical decarbonising is the only maintenance job most owners will normally tackle on the Villiers engine and full instructions are given on page 48.

The exploded drawing on page 24 is self-explanatory, but despite the apparent simplicity of the engine we strongly advise the average owner not to attempt major repair jobs himself, but to entrust the work to a qualified mechanic or to our own Service Department. Splitting and re-assembling the crankcase halves, for instance, is a difficult matter demanding great care and skill, while considerable experience is needed to replace a big end assembly and true the shafts. The James Repairs Department is fully equipped and major repairs entrusted carry a full three months' guarantee. With these facilities at the disposal of James owners, we feel that it will repay our customers not to attempt too much, but to keep within the limits of this book.

### SYMPTOMS OF ENGINE WEAR.

#### BEARINGS.

After considerable service or as a result of inadequate lubrication or negligent driving, wear may occur in the mainshaft and connecting rod bearings.

In both cases the engine will become noticeably rough and probably produce rumbling noises in the case of worn main bearings and definite knocking sounds with a worn big end bearing. Small end wear alone is of little importance and is difficult to detect.

Main bearing wear can be checked by removing the flywheel magneto cover and feeling for up and down movements of the mainshaft by attempting to lift the flywheel.

To check big end wear, remove cylinder head, carburettor and cylinder. Hold the connecting rod firmly in the hand and feel for up and down movement at the bearing. Sideways movement of the connecting rod can be ignored.

If either main bearing or big end bearings are worn, owners are advised to have a replacement crankshaft assembly fitted.

#### CYLINDER.

Cylinder wear will normally occur only after a long period, but premature wear can be caused by careless running-in or insufficient or poor quality lubricant. The most obvious symptom will be a general drop in performance.

Lack of power can, of course, be due to reasons other than cylinder wear, but if after checking ignition and carburation engine performance is still below normal, strip the engine and examine the piston rings, piston and cylinder walls for signs of wear in the form of burns, score marks, cracked rings and ovality of the cylinder bore. If the bore is clean, replacement piston rings will often improve engine performance. If a rebore is required, oversize pistons and rings are available (.015" O/S—.030" O/S). Always fit new cylinder base washer when re-assembling the engine. The cylinder head washer may not appear to be damaged but it is advisable to fit a new one each time the head is removed.

MODEL J15 150 cc. CADET — ENGINE AND CLUTCH. Mark 30C Engine Unit.

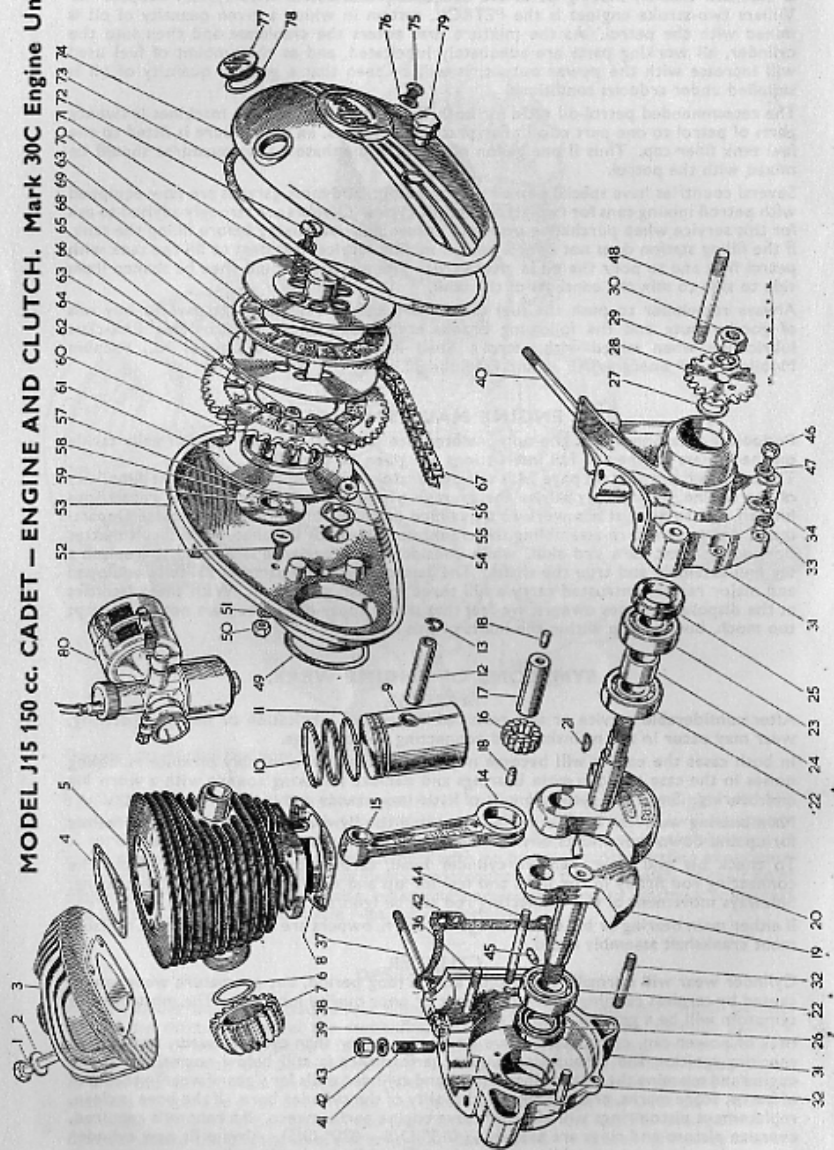

MODEL J15 CADET — ENGINE.

- |   |   |
|---|---|
| 1 Cylinder head bolt.   | 40 Gearbox fixing stud, long.                 |
| 2 Washer.   | — Gearbox fixing stud, short.                 |
| 3 Cylinder head.  | 41 Stud in crankcase for cylinder.            |
| 4 Gasket for cylinder head.   | 42 Spring washer.                             |
| 5 Cylinder.   | 43 Nut.                                       |
| 6 Washer—cylinder head.   | 44 Stud securing crankcase halves—short.      |
| 7 Nut for exhaust pipe.   | 45 Crankcase dowel.                           |
| 8 Gasket for cylinder base.   | 46 Crankcase drain plug.                      |
| 9 Piston.   | 47 Washer.                                    |
| 10 Piston ring.   | 48 Stud for chaincase.                        |
| 11 Expander ring.   | 49 Gasket.                                    |
| 12 Gudgeon pin.   | 50 Nut.                                       |
| 13 Circlip.   | 51 Spring washer.                             |
| 14 Connecting rod.  | 52 Breather valve for chaincase.              |
| 15 Small end bush.  | 53 Chaincase, inner, with gland plate.        |
| 16 Rollers for crankpin—12 steel $\frac{1}{8}'' \times \frac{1}{8}''$ . | 54 Locking plate.                             |
| 17 Crankpin.  | 55 Screw.                                     |
| 18 Crankpin plug.   | 56 Cone nut for inner chaincase.              |
| 19 Crankpin—Right hand.   | 57 Felt washer.                               |
| 20 Crankshaft—Left hand.  | 58 Gland plate.                               |
| 21 Key for engine sprocket.   | 59 Rivets for gland plate.                    |
| 22 Mainshaft ball bearing.  | 60 Dowels for outer chaincase.                |
| 23 Mainshaft ball bearing.  | 61 Clutch centre assembly.                    |
| 24 Distance piece for bearings.   | 62 Clutch sprocket assembly.                  |
| 25 Oil seal—crankshaft drive end.                                       | 63 Cork for clutch sprocket and corked plate. |
| 26 Oil seal—crankshaft magneto end.                                     | 64 Ball retaining plate.                      |
| 27 Shim for engine sprocket.  | 65 Ball.                                      |
| 28 Engine sprocket.   | 66 Rivet.                                     |
| 29 Spring washer.   | 67 Primary chain.                             |
| 30 Nut.   | 68 Centre plate.                              |
| 31 Crankcase, right and left hand halves, less fittings.                | 69 Corked plate.                              |
| 32 Stud securing crankcase halves.                                      | 70 Front plate assembly.                      |
| 33 Washer.  | 71 Spring.                                    |
| 34 Nut.   | 72 Screw.                                     |
| 35 Stud securing crankcase halves.                                      | 73 Gasket.                                    |
| — Washer.   | 74 Chaincase, outer.                          |
| — Nut.  | 75 Chaincase, oil level screw.                |
| 37 Gearbox fixing stud, top right.                                      | 76 Washer.                                    |
| 38 Gearbox fixing stud, washer.   | 77 Oil filler plug.                           |
| 39 Gearbox fixing stud, nut.  | 78 Washer.                                    |
| — Gearbox fixing stud, medium.  | 79 Domed nut.                                 |
|   | 80 Carburetter.                               |

The clutch requires no attention beyond that of lubrication and correct adjustment of push rod to give the necessary clearance to prevent clutch slip. Whilst the clutch is engaged, i.e., driving, there must be a clearance between end of push rod and the clutch lever fitted to gearbox. A special adjuster having a knurled and slotted head is provided so that adjustment can be made without tools. There should be  $\frac{1}{16}''$  free movement at end of gearbox clutch lever before commencing to depress the clutch springs.

DISMANTLING THE CLUTCH.

To strip the clutch and to gain access to the driving sprockets proceed as follows: Remove primary chaincase cover retained by large domed nut (79), remembering to place a pan underneath to receive the oil.

Loosen engine sprocket (28) by placing "hammer tight" spanner over the locking nut (30) and giving the spanner a sharp blow with the hand gripped round the clutch springs. It will be found that this will loosen the nut sufficiently for it to be unscrewed by hand.

Unscrew the six clutch springs (69 and 70), withdraw metal plates and intermediate cork-insert plate to expose clutch sprocket (60).

Remove engine and clutch sprockets simultaneously with chain. The former is keyed on a parallel shaft. There are  $50 \frac{3}{16}''$  ball bearings in the clutch sprocket.

Unscrew the nut (ill. No. 12, p.26) holding the clutch centre assembly (59) by inserting a strong screwdriver between shafts of assembly in such a manner as to prevent its rotation. The assembly is splined on the shaft and no key is therefore fitted.

Remove engine sprocket key, unscrew nut and washer at back of chaincase, over gearbox. Next, remove small screw (55) and locking plate (54), below and to the left of the clutch shaft. The nut retained by these parts may now be taken away, when the rear half of the chaincase will be freed. Withdrawal of the case will expose the countershaft or final drive sprocket, held in place by a large thin nut and locking screw. (When re-assembling do not forget to replace the latter and also the engine sprocket key and locking plate).

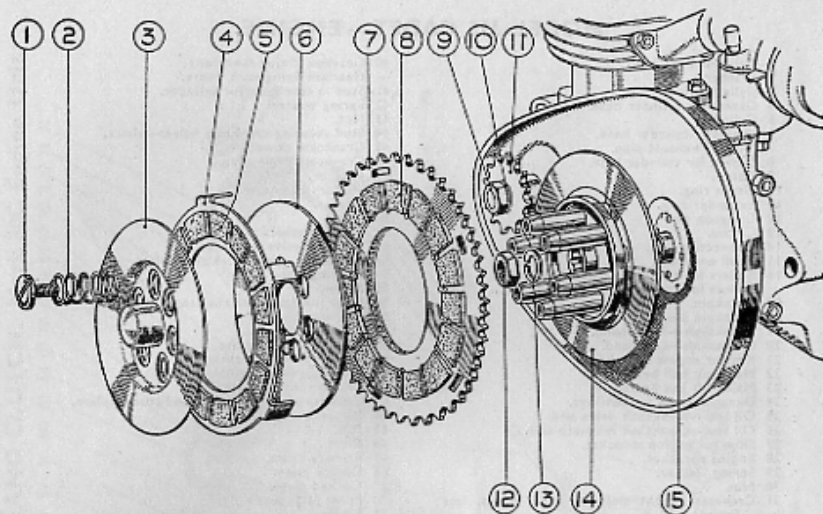

- |                             |                             |
|-----------------------------|-----------------------------|
| 1 Clutch spring screw.      | 9 Engine sprocket nut.      |
| 2 Clutch spring.            | 10 Engine sprocket shim.    |
| 3 Chaincase gland plate.    | 11 Engine sprocket.         |
| 4 Clutch plate—corked.      | 12 Mainshaft nut.           |
| 5 Cork insets.              | 13 Mainshaft spring washer. |
| 6 Clutch centre plate.      | 14 Clutch body.             |
| 7 Clutch sprocket assembly. | 15 Oil seal.                |
| 8 Cork insets.              |                             |

When removing the final drive sprocket do not take off the rear chain; apply the rear brake so that the sprocket is tightly held by the chain. The same will apply when replacing the sprocket and tightening the nut.

Reverse the order of removal when rebuilding.

#### GEARBOX AND PRIMARY CHAINCASE LUBRICATION.

Always specify one of the recommended makes and grades of oil. Do not overfill either the gearbox or the chaincase, excessive lubricant can cause nearly as much trouble as the lack of it. A dipstick is provided on the gearbox and the level should be checked as often as possible. When refilling remove the level plug (item 12, page 36) at the back of the gearbox and fill until oil runs out of the plug-hole.

Similarly, on the chaincase, oil should be at plug-hole (item 75, page 24) level when the machine is on an even surface.

#### MODEL J15 CADET — MAGNETO.

The purpose of the high tension magneto is to produce a hot spark across the points of the sparking plug. The voltage required to produce this spark will vary according to the conditions. In a cold engine the voltage may have to be as high as 10,000 volts, but when the engine is warm, a voltage of between 4,000 and 6,000 will be sufficient to jump across the plug points. A magneto consists principally of permanent magnets, a high tension coil, a contact breaker and a condenser. In this magneto the magnets are secured to the rotating flywheel, and the high tension coil, contact breaker and condenser are stationary.

The Villiers flywheel magneto has six poles and provides current for both ignition and lighting. The same magneto is used for both DIRECT and RECTIFIER-BATTERY lighting sets although wiring connections differ and reference should be made to the wiring diagrams on pages 29 and 30.

If it is necessary to remove the flywheel magneto, a special "Hammer Tight" spanner (available from Service Dept. part No. 703124) should be used on the centre nut exposed on removal of the flywheel cover. The centre nut is imprisoned in the flywheel and acts as an extractor when turned anti-clockwise.

The armature plate which carries the ignition coil, lighting coils and contact breaker assembly is secured to the crankcase by four screws. The high tension lead from ignition coil to sparking plug is detachable by unscrewing from armature plate, and when refitting it is important to make sure that the brass pad carried by the spring and secured to the terminal makes contact with the soldered disc on the outside of the ignition coil.

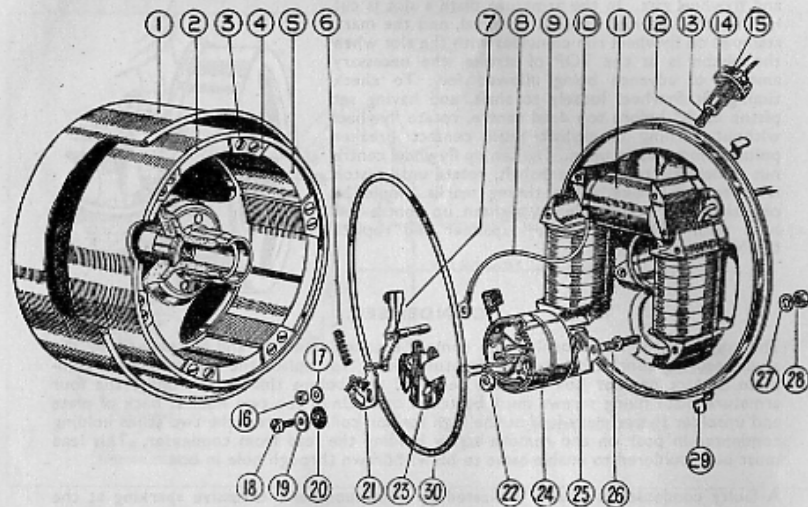

- |                               |                               |                                |
|-------------------------------|-------------------------------|--------------------------------|
| 1 Flywheel cover.             | 10 H.T. coil end—right-hand.  | 21 Point bracket.              |
| 2 Flywheel assembly.          | 11 H.T. coil.                 | 22 Point bracket adjuster cam. |
| 3 Screw, pole shoe.           | 12 H.T. terminal pad.         | 23 Insulating pad.             |
| 4 Top plate, pole shoe, iron. | 13 H.T. terminal spring.      | 24 Condenser box.              |
| 5 Magnet.                     | 14 H.T. terminal felt washer. | 25 Condenser.                  |
| 6 Rocker arm spring.          | 15 H.T. terminal.             | 26 Condenser box fixing stud.  |
| 7 Rocker arm.                 | 16 Nut, L.T. lead.            | 27 Washer for stud.            |
| 8 Low tension lead.           | 17 Brass washer.              | 28 Nut for stud.               |
| 9 Lighting coils with cheeks. | 18 Lockscrew, point bracket.  | 29 Flywheel cover clip.        |
| 10 H.T. coil end—left-hand.   | 19 Brass washer.              | 30 Cover joint ring.           |
|                               | 20 Insulating washer.         |                                |

#### CONTACT BREAKER.

Only a screw-driver is required to adjust the contact breaker points. To do so proceed as follows:

Turn flywheel clockwise until rocker pad is on top of cam profile of flywheel boss. Release screw "A". Position bracket "B" by turning adjuster cam "C" until .015" feeler gauge can be inserted between contact points. Tighten screw "A" and withdraw feeler gauge. It is not necessary to disturb nut "D" when adjusting point gap.

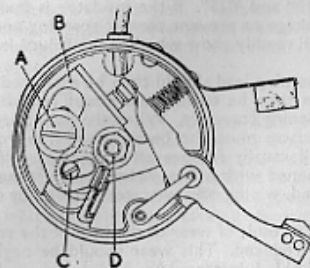

A hard felt pad is used to keep the cam in a slightly oily condition, and is impregnated with grease when new. This can, if visibly dry, be oiled with a small amount of the thickest oil available. If too much oil is put on the pad, it may creep along the rocker arm, get on the points and so cause ignition trouble.

#### TIMING THE MAGNETO.

Timing marks are provided on the armature plate and flywheel rim. In the armature plate a slot is cut in line with the high tension terminal, and the mark stamped on flywheel rim coincides with the slot when the piston is at the TOP of stroke, the necessary amount of advance being allowed for. To check timing, fit flywheel loosely to shaft, and having set piston at  $\frac{1}{8}$ " before top dead centre, rotate flywheel without turning crankshaft until contact breaker points commence to open. Tighten up flywheel centre nut sufficiently to turn crankshaft, rotate until piston is at top of stroke, when timing marks should be opposite each other. Finally, tighten up centre nut hard with "Hammer Tight" spanner and replace flywheel cover.

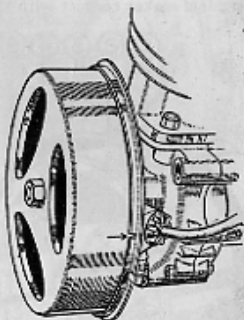

#### CONDENSER.

The condenser is fitted behind the contact breaker assembly and is retained by the studs securing contact breaker to armature plate. To replace the condenser, the complete contact breaker box must be removed and before this can be done, the four armature plate fixing screws must be taken out. Undo the two nuts at back of plate and unsolder the primary lead at the high tension coil. Unscrew the two studs holding condenser in position and remove screw holding the lead from condenser. This lead must be unsoldered to enable same to be withdrawn through hole in box.

A faulty condenser is usually indicated by continuous and excessive sparking at the contact points, but before fitting a new condenser, make sure the studs holding the condenser are really tight to ensure a good EARTH. Occasional sparking is normal and may be ignored.

#### IGNITION FAILURE.

The cause of ignition failure will generally be found to be due to the condition of the sparking plug or contact breaker points, or faulty insulation of plug wire or contact breaker connections. Serious trouble in the form of condenser or coil breakdown is very rare.

The first step in dealing with ignition trouble should be to remove plug from engine and examine the points to see whether they are oily and the gap correctly set between .018" and .025". If the insulator is fouled with oil and carbon, there may be sufficient leakage to prevent correct sparking and cleaning will be necessary. Fitting a new plug will readily show whether the failure is due to plug or not.

The plug lead should then be examined for cracks or other faults. The contact breaker can then be examined without removing the flywheel to see whether the points are opening correctly. When the points are fully open there should be a gap of .015". The surfaces must also be clean and free from oil and severe pitting. A piece of stiff paper will usually remove oil or grease. If the points are burned or pitted they should be cleaned with a fine carborundum stone if available, otherwise fine emery cloth can be used, wiping off any traces of metal or emery dust with a petrol-soaked rag.

As a result of wear of the heel of the rocker arm bearing on the cam the point gap will be reduced. This wear should be negligible if the felt oiling pad is kept moist with suitable lubricant.

#### MODEL J15 CADET — DIRECT LIGHTING EQUIPMENT.

The James Cadet is normally fitted with a Direct lighting system in which the alternating current is taken direct from the lighting coils in the flywheel generator to the lamps via the headlamp switch.

A twin cell dry battery housed in the toolbox provides current for parking lights, and owners are advised to make maximum use of the Direct lighting and to use the battery for parking purposes only. The dry battery should be thrown away when exhausted, replacement being perfectly straightforward.

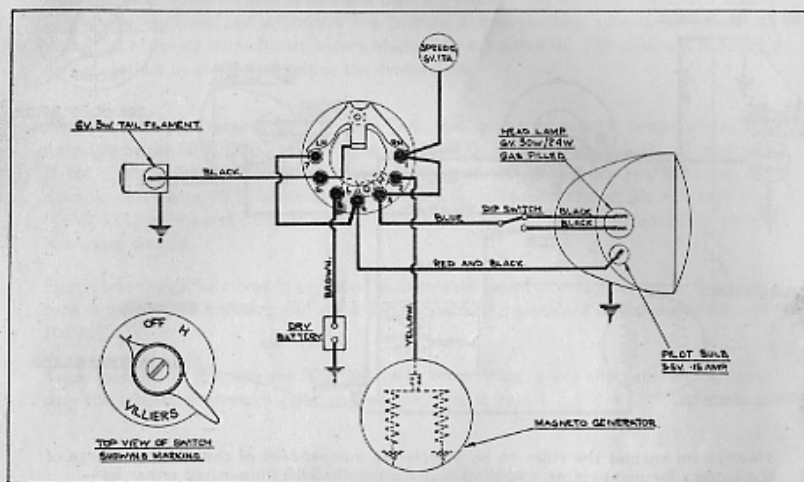

#### HEADLAMP.

The main bulb has twin filaments, one filament providing the main driving beam and the other a dipped beam, brought into operation by the dipper switch on the left handlebar, when required. The pilot bulb is mounted behind the reflector and shines through a small window in the reflector under the main bulb.

The design of the lamp holder, lamp and reflector assembly is such that when the bulb is correctly positioned, no focussing is required.

The reflector and front glass are made up as one assembled light unit, and no attempt should be made to separate them. The components cannot be purchased separately.

#### REMOVING LIGHT UNIT AND HEAD LAMP RIM.

Slacken the screw on top of the lamp body at the front, pull the rim outwards from the top and, as the front comes away, lower slightly to disengage bottom tag from lamp shell. Twist the back shell in an anti-clockwise direction and pull it off. The main bulb can then be removed from its housing in the reflector assembly. The lamp rim is secured to the light unit by spring clips which can be removed by pressing with a screwdriver blade, at the same time working away from the edges.

#### REPLACING RIM AND LIGHT UNIT.

Lay the light unit in the rim so that the location block on the unit engages with the forked brackets on the rim. Replace the clips by springing in, so that they are evenly spaced around the rim. To replace the back shell, engage the projections on the inside of the back shell with the slots in the holder, press on and secure by twisting it to the right. Engage bottom tag on headlamp rim with the small slit in the shell, and gently force the top of the rim back into the shell, after which re-tighten the locking screw on top of the lamp body.

FOR CORRECT REPLACEMENT BULBS SEE DATA PAGE 55.



## AC/DC RECTIFIER BATTERY LIGHTING SET.

The 150 cc. Cadet is normally fitted with a direct lighting system but since a Rectifier Battery lighting system can be fitted by using the same flywheel generator, details of the rectifier system are included in this booklet. As will be seen from the accompanying diagram, the wiring connections differ from the Direct lighting equipment described on page 29.

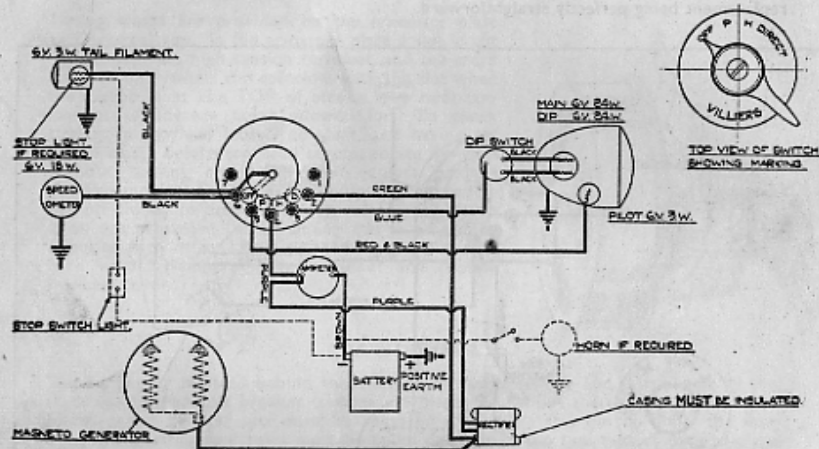

This system enables the rider to be completely independent of the state of charge of the battery for night riding, and the headlamp bulb may be illuminated either by—

- A.C. current direct from the generator (switch position marked "Direct")
- or
- D.C. current from the battery (switch position marked "H").

Parking lights and all other accessories are always operated from current obtained from the battery (switch marked position "P").

When the switch is in the "Direct" position no light can be obtained at the main bulb when the engine is not running, because, in this position the headlamp bulb is not connected to the battery and no current is being produced by the generator. In all the other switch positions the lamps are independent of engine speed, as they are connected to the battery through the headlamp switch.

It is recommended that the "Direct" position should be used on every possible occasion, as this means no current is being taken from the battery by the headlamp. In addition to this, a small charge will also be given to the battery when the engine is running at moderate speeds.

There are two very important precautions which **MUST** be observed in the assembly of this type of lighting set.

1. **THE RECTIFIER CASING MUST BE COMPLETELY INSULATED FROM THE FRAME.** The essential is that there should be no direct metallic connection between the casing of the rectifier and any part of the motorcycle.
2. **THE POSITIVE TERMINAL OF THE BATTERY MUST BE CONNECTED TO EARTH.**

**Note:** In some cases the lead shown on the diagram connecting the generator to the rectifier, may be replaced by a lead from the generator to the No. 2 terminal in the switch. This does not effect the operation in any way.

## BATTERY.

Models with rectifier/battery lighting equipment are supplied with "dry charged" batteries—Lucas type PUZ7E-9, capacity 6 volt, 12 amp hours.

Machines with Lucas "Drycharged" batteries are supplied to dealers without electrolyte, but with their plates in a charged condition. No initial charging is required and to bring the battery into service it is only necessary to fill the cells with electrolyte, prepared by mixing concentrated sulphuric acid and distilled water. The cell filler holes are sealed to exclude moisture and air before the battery is brought into service and the seals should be removed immediately before electrolyte is poured in. This task will normally be undertaken by the dealer selling the motorcycle.

**Preparation of Electrolyte:** In the U.K. and countries where temperatures are normally below 90°F. (32°C.) electrolyte of 1.270 S.G. is recommended, viz: 1 part acid (1.835 S.G.) to 2.8 parts distilled water. In tropical climates where temperatures frequently rise above 90°F., electrolyte of 1.210 S.G. is recommended, viz: 1 part acid (1.835 S.G.) to 4 parts distilled water. When mixing, acid should be added to water, not water to acid.

Electrolyte should be mixed in a glass or earthenware vessel or lead lined tank. Temperature of filling room, battery and electrolyte should be maintained at between 60°F. and 100°F.

Batteries filled in this way are 90% charged. After filling, a dry charged battery needs only the attention normally given to lead-acid type batteries.

## BATTERY MAINTENANCE.

Deterioration soon sets in if the battery is left standing without attention for any length of time. To keep the battery in good condition, maintenance must be carried out whether the machine is in use or not.

Every month (every fortnight in summer), remove battery from the machine clean terminals, and top-up the three cells to  $\frac{1}{4}$ " above the level of the plates with distilled water—NOT tap water, as this contains impurities detrimental to the battery. Pour the distilled water through a glass funnel or syringe.

Many lighting troubles can be traced to unseen corrosion between the surfaces of the battery terminals; the positive is earthed to reduce this effect to a minimum, but keep the terminals clean. A little grease smeared on them will help prevent corrosion. Do not keep distilled water in receptacles made of any kind of metal as this will quickly render it impure—make use of a clean glass bottle or jar. Rainwater collected in a jar makes a satisfactory substitute for distilled water.

**NEVER** bring a naked light near a battery with vent plugs removed or when the battery is being charged; the gas given off by the electrolyte is dangerously explosive.

Battery acid is highly corrosive; therefore throw away any cleaning rags used to clean the battery lest their use on other parts of the machine causes damage.

**NEVER** let a battery completely run down; if this does occur, get it charged as soon as possible, or its length of life may be seriously shortened.

### MODEL J15 CADET CABURETTER.

Villiers Type S.19.

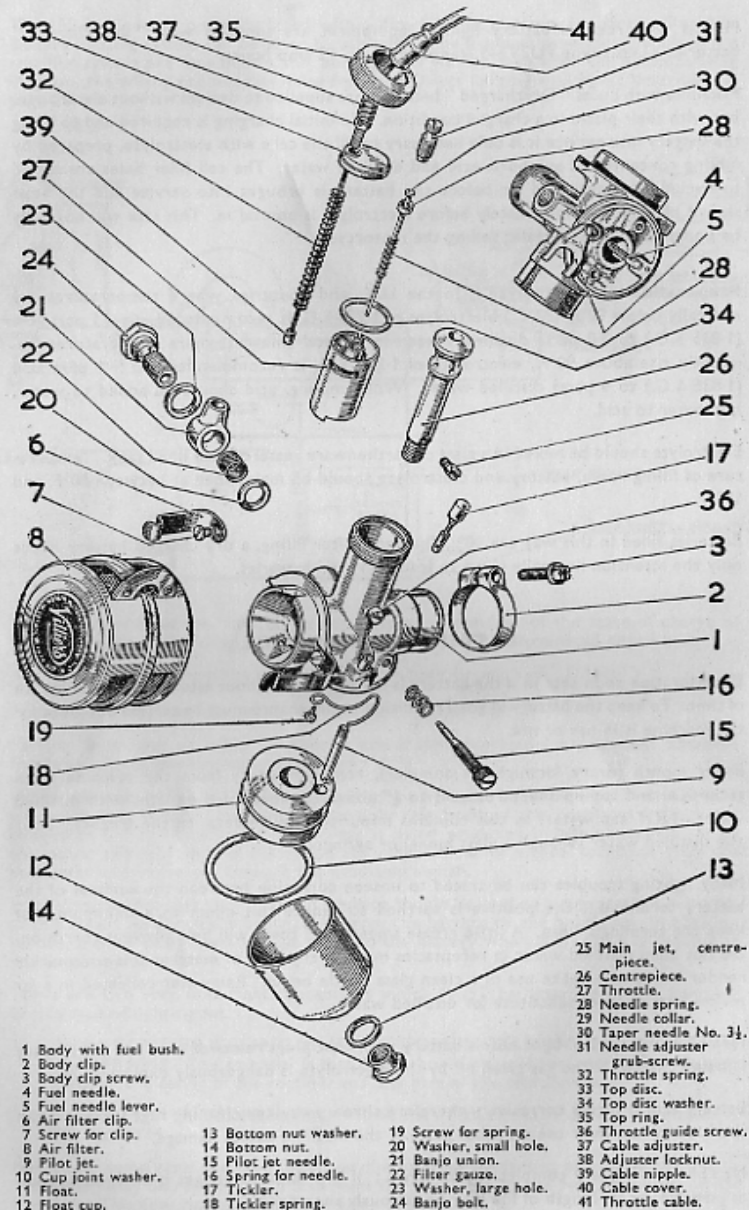

### MODEL J15 CADET — CARBURETTER.

The Carburetter fitted to the 150 cc. Cadet engine is the Villiers Type S.19. In this carburetter the position of taper needle in relation to the throttle is adjustable by means of the grub screw situated in centre at top of throttle. This adjustment is provided to suit individual engines, and it should not be necessary to alter the makers setting except after considerable mileage. The standard setting from throttle to end of taper needle is 2.015 ins.

#### OPERATION OF CARBURETTER.

The handlebar twistgrip control operates the throttle slide and thereby regulates the amount of mixture entering the engine, whilst the carburetter itself automatically meters and atomises the correct amount of fuel to give the necessary mixture strength. To achieve this automatic control of the mixture strength, two separate fuel systems are fitted, namely the main-jet and pilot-jet systems. At idling speeds the carburetter draws fuel from the pilot-jet and, as the throttle is gradually opened, the fuel is then drawn in turn from the pilot "progression" hole and the main-jet system. The operation of the two systems is given below :—

#### 1(a) Pilot-Jet System.

At idling speeds, when the throttle is nearly closed, the pilot outlet hole (A) is subject to the very high engine suction, and petrol is, therefore, drawn from the float chamber through the pilot tube (B) and the pilot outlet hole. The calibrated pilot-jet is contained in the top of the pilot tube. At the same time, a filtered supply of air is drawn from the mouth of the carburetter through passage (C) through the variable air-jet (D) and is then pre-mixed with the fuel in the small chamber (E). The pilot adjuster screw (F) varies the size of the pilot air jet, and therefore, the pilot mixture strength—to richen mixture, turn screw clockwise.

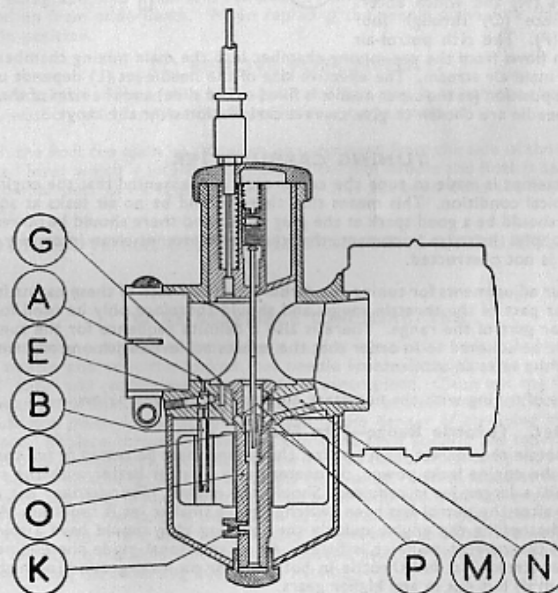

When the throttle slide is opened a small amount beyond that required for idling, the suction on the pilot outlet hole is reduced, but at the same time, the suction on the pilot "progression" hole (G) increases. A further supply of petrol is, therefore, drawn

through the "progression" hole, and prevents the weak spot which would otherwise occur due to the fall off in supply from the pilot hole before the main jet comes into full operation.

It follows from the preceding remarks that whenever the throttle is shut off whilst the engine speed is high (such as on long downhill sections) the pilot system is subject to the full engine suction, and petrol will flow into the engine from the pilot outlet hole. As the engine is not firing under these conditions, this fuel supply will tend to build up in the crankcase and cylinder and cause severe "four-stroking" or "eight-stroking" when the throttle is opened again. To overcome this fault an automatic air bleed to the pilot has been incorporated, which relies upon the matching of two slots, one in the throttle slide and the other in the carburettor body. When the throttle slide is shut, two slots line up and air can flow from the front of the carburettor through the throttle slide and down passages H and J into the pilot system. The high depression on the pilot system is then destroyed. In all other throttle positions, the two slots do not line up, and no air can pass to the pilot system through these passages.

#### 1 (b) Main Jet System.

As the throttle slide is opened further beyond the idling and progression positions, the engine suction has its effect upon the main-jet system, and petrol is drawn from the float chamber through the calibrated main jet (K) and the needle-jet (L) and into the small pre-mixing chamber (M). There the petrol is atomised by the filtered secondary air which is drawn from the mouth of the carburettor along passage (N) and which enters the centre-piece (O) through four small holes (P). The rich petrol-air mixture then flows from the pre-mixing chamber into the main mixing chamber, where it meets the main air stream. The effective size of the needle-jet (L) depends upon the throttle slide position (as the taper needle is fixed to the slide) and the sizes of the needle-jet and the needle are chosen to give correct carburation over the range.

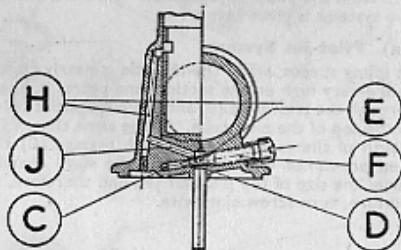

#### TUNING CARBURETTER.

Before any attempt is made to tune the carburettor it is essential that the engine is in a good mechanical condition. This means that there should be no air leaks at any of the joints, there should be a good spark at the plug points and there should be no restriction in the fuel supply. It is also important, that the carburettor is clean internally and that the air filter is not obstructed.

There are four adjustments for tuning the carburettor, but each of these has its full effect at a particular part of the throttle range, and should therefore only be used for tuning that particular part of the range. There is also a definite sequence for the tuning, and this also must be adhered to in order that the results achieved with one adjustment are not upset by the next adjustment.

The sequence of tuning with the necessary adjustments is given below :—

#### (2) Main Jet. Throttle Range— $\frac{2}{3}$ to Full.

In order to obtain the correct main jet size, the engine must be tested at full throttle in top gear. If the engine lacks power, detonates badly or runs better with the strangler slightly closed, a larger jet is required. Should the engine "four-stroke" or improve momentarily after the petrol has been switched off, a smaller jet is required. After de-clutching and stopping the engine quickly the sparking plug should have a shiny black appearance if the correct main-jet is fitted. As an additional guide the engine should tend to "four-stroke" at full throttle in bottom gear on level ground (or high engine speeds in neutral) but not in any higher gears.

#### (2) Pilot Jet. Throttle Range—Closed to $\frac{1}{2}$ Open.

The pilot jet must be set when the machine is stationary with the engine running at the required idling speed. To richen mixture, screw in the pilot adjuster screw, and to weaken, unscrew pilot adjuster. The mixture strength must be set as weak as possible

consistent with a steady reliable idling speed and good engine acceleration from this throttle position. If the mixture strength is set too rich, trouble will be experienced with the fuel build-up in the crankcase when the throttle is shut with the engine still running fast. Should this latter fault be present after adjusting the pilot, unscrew pilot a further half a turn. Any weakness on acceleration can be cured by throttle cut away as given below :—

#### (3) Throttle Cut-Away. Throttle Range— $\frac{1}{2}$ to $\frac{1}{4}$ Open.

The throttle slide is made with a cut-away on the carburettor inlet side which influences the depression on the main-jet system. The throttles are marked with a number which represents, in sixteenths of an inch, the amount of cut-away. A throttle with more cut-away will give weaker mixtures (over the particular throttle range) and vice-versa. If the acceleration is weak, fit throttle with smaller cut-away. Should the engine tend to "four-stroke" when the throttle is shut, fit a larger cut-away.

#### (4) Needle Adjustment. Throttle Range— $\frac{1}{2}$ to $\frac{3}{4}$ Open.

The needle is adjusted by the grub screw in the top of the throttle—screw down to weaken mixture, and vice-versa. The needle controls the mixture strength over most of the "cruising range" and must be correct for good fuel consumption and acceleration. After carrying out the above adjustments, it is wise to go back and re-check the pilot adjustment to see that this has not been affected by other adjustments.

#### TO CHANGE THE TAPER NEEDLE.

Remove throttle from body after unscrewing the top ring, and in the centre at top of throttle will be found a small slotted grub screw. This is the adjuster referred to in the previous paragraph, and when it is removed by unscrewing, the needle with spring can be pushed up from underneath. When replacing the needle make sure that the needle collar is in position.

#### TO REMOVE FUEL NEEDLE.

If it is necessary to remove the fuel needle the first step is to remove the bottom nut and fibre washer which enables the float chamber to be taken off.

To detach the float the main jet (K) must be unscrewed from the side of the centre-piece. The forked lever which is interposed between the fuel needle and float is split to enable it to be pulled clear of its retaining pin. After this has been done the fuel needle will drop away.

#### DO NOT REMOVE THE CENTREPIECE FROM THE CARBURETTER BODY.

#### TO RE-ASSEMBLE CARBURETTER.

Clean the various components and make sure that the tickler vent hole is clear. Insert the fuel needle and refit the forked fuel needle lever. Place float in position, this is marked "top," and replace main jet in side of centre-piece. Clean out the float cup and replace with large fibre joint washer at top. Replace bottom nut and fibre washer but do not use too much force, otherwise there is the danger of stripping the thread of centre-piece. Replace throttle in body at the same time guiding the taper needle into hole in top of centre-piece. A guide screw in the carburettor body will prevent the throttle being replaced unless it is correctly positioned. Locate top disc in top of body and screw on top ring. If the carburettor has been removed from the engine, make sure when re-fitting that the body is pushed on to the manifold as far as possible, and that it is set upright. There are four narrow slots in the body to allow the securing clip to function, and if the manifold stub does not extend past the end of the slots, air will be sucked in causing hard starting and erratic running.

The carburettor has a banjo petrol pipe fitting inside of which is a fine mesh filter gauze which should be periodically cleaned by dipping in petrol. Be sure that when replacing the petrol pipe the fibre washers make a petrol tight joint, otherwise fuel will be wasted. The air filter should be cleaned every 2,000 miles by washing in petrol. Following this the filter should be dipped in thin oil and allowed to drain before refitting.

## MODEL J15 150 cc. CADET—THE VILLIERS THREE SPEED GEARBOX

- 1 Gearbox, bushed.
- 2 Oil bearing.
- 3 Oil filler plug.
- 4 Sprocket distance piece.
- 5 Sprocket standard, 18 teeth.
- 6 Sprocket locknut.
- 7 Screw for locknut.
- 8 Spring washer.
- 9 Sealing disc.
- 10 V.I. filler plug.
- 11 Oil drain plug.
- 12 Washer for plug.
- 13 Layshaft bush.
- 14 Stud for end plate.
- 15 Dowel.
- 16 Selector pivot pin.
- 17 Selector quadrant.
- 18 Plunger.
- 19 Plunger spring, short.
- 20 Oil level plug.
- 21 Washer for plug.
- 22 Mainshaft.
- 23 Pressure washer.
- 24 Mainshaft fixed pinion.
- 29

- 30 Layshaft.
- 31 Layshaft fixed pinion.
- 32 Layshaft sliding pinion.
- 33 Ratchet gear operator.
- 34 Ratchet.
- 35 Push rod, headed.
- 36 Push rod, long.
- 37 Push rod, short.
- 38 Steel washer.
- 39 Felt washer.
- 40 Kickstart shaft, bushed.
- 41 Kickstart pawl.
- 42 Kickstart plunger.
- 43 Plunger spring.
- 44 Sealing ring.
- 45 Operating spindle.
- 46 Sealing ring.
- 47 Pressure washer.

- 48 Spindle circlip.
- 49 Foot change lever.
- 50 Bolt lever for lever.
- 51 Bolt lever.
- 52 Nut for bolt.
- 53 Ratchet spring.
- 54 Operating pawl.
- 55 Operating pawl spring.
- 56 Operating spindle plate.
- 57 Operating spindle distance piece.
- 58 Operating lever.
- 59 Operating shim.
- 60 Operating spindle washer.
- 61 Operating lockwasher.
- 62 Operating nut.
- 63 Stop pin.
- 64 Plunger box.
- 65 Plunger box nut.
- 66 End plate, bushed.

- 67 Mainshaft bush.
- 68 Adjuster bush.
- 69 Adjuster locknut.
- 70 Bush for kickstart shaft.
- 71 Bush for kickstart shaft.
- 72 Kickstart stop piece.
- 73 Dipstick.
- 74 Washer for dipstick.
- 75 End plate nut.
- 76 End plate screw.
- 77 Dust cover.
- 78 Dust cover screw.
- 79 Washer for dipstick.
- 80 Adjuster locking plate.
- 81 Fixing screw.
- 82 Clutch adjusting screw.
- 83 Clutch lever.
- 84 Return spring.
- 85 Cap for spring.
- 86 Kickstart lever.
- 87 Kickstart pawl.
- 88 Pedal pivot pin.
- 89 Ball for pivot pin.
- 90 Spring for ball.
- 91 Sald.
- 92 Washer.
- 93 Nut.

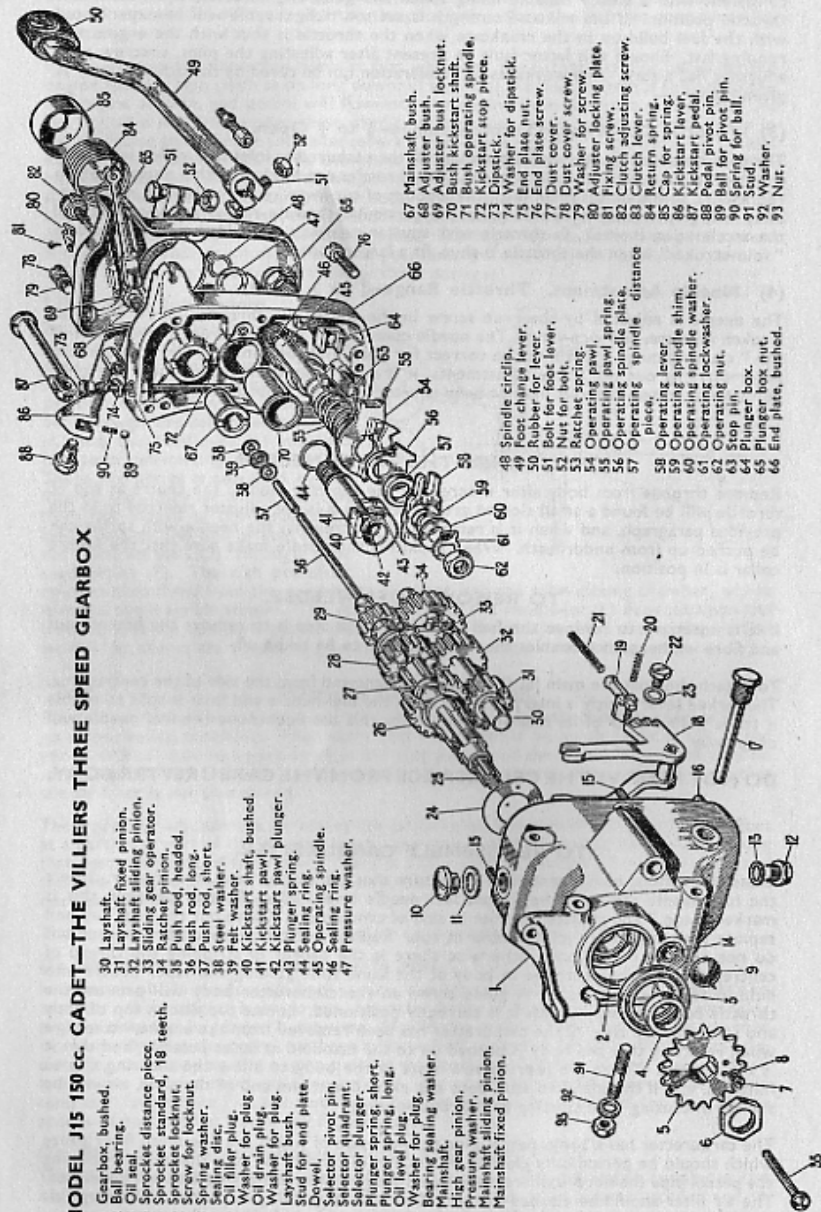

## MODEL J15 CADET — GEARBOX.

If it is necessary to gain access to the interior of the gearbox proceed as follows :  
Drain oil through bottom plug (12).

Remove kick-starter lever (86) and foot gear control (49). Both are retained on their splined shafts by pinch bolts (51).

The gearbox dust cover (77) is held by three screws ; removal of this cover will give access to the bushed end plate (66). The clutch lever (83) will then come away, as it is held only by pressure of the clutch adjuster (82). Unscrew clutch cable adjuster at top left of end plate.

The end plate is retained in position by three screws and three hexagon nuts. Before removing them however, loosen large domed nut (65) alongside the foot lever shaft; this houses the selector plunger assembly. When all nuts and screws are removed, the plate will be ready to slide off : remove, leaving kick-starter shaft (40) in position in low gear ratchet pinion. If need be, the kick-starter pawl (41) may be removed by pressing down spring and plunger and sliding the pawl along its seating.

The mainshaft cannot be removed unless the clutch unit has been dismantled as described on page 31. When this has been done, the mainshaft will come away, leaving final drive sprocket (5) and high gear sleeve pinion (26) in position. The layshaft (30) may be withdrawn most easily by taking out the selector quadrant (18) retained by a bearing pin at the side of the box.

To replace the layshaft, pinion assembly and sliding pinion operator (33), push the layshaft right into its bush, ensuring the operator is correctly fitted. Before fitting the end plate, remove the selector plunger (19) and spring, and place kick-starter shaft in the end plate bush, turning it to its stop pin (63). This will facilitate pushing the plate home.

The positive stop gear change mechanism at the back of the end plate should not be interfered with unless absolutely necessary, as it is very easy to re-assemble incorrectly. If, for any reason, dismantling is required, follow the order of assembly shown on the exploded drawing very closely.

The end plate and dust cover are thin aluminium alloy castings and when replacing fixing screws and nuts it is important that the respective washers should be in their recesses. The hexagon nut washers **MUST** be fitted, or a cracked dust cover may ensue. Clean all faced joints with petrol when re-fitting, using a jointing compound such as gold size.

The mainshaft fixed pinion (29) engaging with the layshaft ratchet pinion is a press fit on the mainshaft and cannot be easily removed whilst in the gearbox. This also applies to the fixed pinion on the layshaft (31).

If all the parts are correctly fitted and positioned, the end plate will slide home without difficulty. If it will not do so, do not force it on, but find out the reason.

It is best to strip and re-assemble the gearbox with the gears in the NEUTRAL position ; you can then ensure that the knob on the selector quadrant assembly is properly placed in the fork of the operating lever (58).

### ADJUSTMENT OF MAINSHAFT.

This is carried out by means of the barrel adjuster (82) in the dust cover end plate. Slacken slotted locknut (69) and turn barrel centre gently in a clockwise direction until only a trace of end play exists. Tighten collar securely. To avoid premature wear, leave a little end play (about .002").

After re-assembling gearbox, engage gears one by one to make sure everything is in working order.

## MODEL J15 CADET — FOOT CHANGE MECHANISM.

We do not recommend that the foot change mechanism should be removed, but if this is necessary for any replacement of the parts, proceed as follows :

Remove the circlip outside the cover on the end of the foot change spindle ; the shaft will then slide out complete with all the ratchet members. In order to strip down the shaft, turn down the locking plate tab (61) and hexagon nut (62). Note the position of all the parts before dismantling, as it is easy to re-assemble incorrectly, which will prevent the mechanism from working at all. Do not lose or damage the phosphor bronze shims (59) found under the washer with the "D" shaped hole. Before re-assembling make sure the face teeth on both ratchet members are not damaged. Do not attempt to remove the "D" shaped stop pin which is pressed into the gearbox cover.

## MODEL J11 98 cc. COMET — POWER UNIT. Villiers Mark 4F Engine Gearbox Unit.

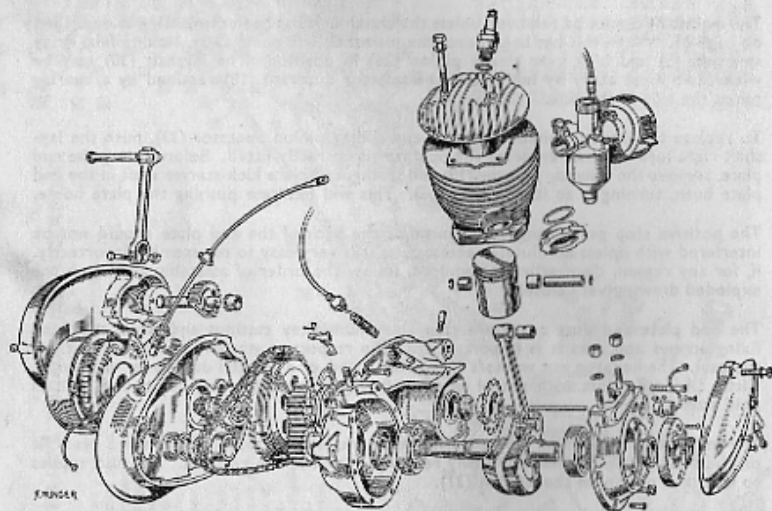

Exploded drawing reproduced by kind permission of "The Motorcycle," London

The Villiers Mark 4F two-stroke engine fitted to the James Comet is a compact unit incorporating a simple and efficient two-speed gearbox. It is a proved and reliable lightweight power unit and will give long and very economical service in exchange for a little occasional attention. The instructions which follow are intended to give the owner a working knowledge of the engine in order that he may maintain it in first-class working order. Should major repairs ever become necessary the work should be entrusted to a qualified motor cycle repairer or ourselves, as considerable damage and expense may be incurred by attempting too much without the necessary equipment and experience.

### DESCRIPTION.

**Crankcase and Gearbox.** This is an aluminium casting in three main parts, enclosing the two-speed gearbox and flywheel magneto. A detachable cover on the left-hand side of the engine encloses the contact breaker mechanism, which for ease of maintenance is located on the crankcase on the opposite side to the flywheel magneto.

**Cylinder.** A deeply finned cast iron cylinder is used, having one inlet, one exhaust, and two transfer ports. The cylinder is secured to the crankcase by four studs.

**Cylinder Head.** Secured to the cylinder by four bolts, the detachable aluminium alloy cylinder head is fitted with a Lodge type H14 14 mm. sparking plug.

**Piston and Connecting Rod.** The aluminium flat-topped piston carries two compression rings, and a special expander ring is fitted inside the lower ring to ensure proper compression when the engine is started from cold.

A floating gudgeon pin is fitted, and is located endwise by circlips. The connecting rod is a steel forging, having a plain bronze bearing at its small end, and at its big end, two rows of steel rollers running on the crankpin.

**Crankshaft.** This is a steel forging in two parts, rigidly joined together by the fitting of the crankpin. At each side, the crankshaft is carried in a large ball bearing which ensures free running and minimum wear. The contact breaker cam is formed on the end of the left-hand half of the crankshaft.

**Carburettor.** A Villiers Junior pattern carburettor is fitted at the rear of the cylinder, being mounted on a stub which is cast integral with the cylinder barrel. Control of the carburettor is by twist grip. A combined air filter and strangler is standard equipment. This is placed within convenient reach of the rider, and ensures easy starting.

**Clutch.** The two-plate clutch has cork inserts, and is controlled by means of a Bowden cable attached to a lever fitted to the left handlebar of the machine.

**Two-speed Gear.** The two gears are engaged by means of a sliding dog mechanism, there being a neutral or "free engine" position between high and low gears. Control is by Bowden cable and a lever on the right handlebar.

### ENGINE MAINTENANCE.

No reference is made in these instructions to complete dismantling of the engine beyond that necessary for normal adjustments and decarbonising. This is because special equipment is needed for dealing with the lower half of the engine, gearbox, etc.

If anything has gone amiss with any of these parts, rather than attempt to take the engine completely to pieces without the proper tools, it will be far better to entrust the work to the dealer from whom the motor cycle was purchased. Alternatively, the complete engine can be returned to James Service Department for the most expert attention.

If, for any reason, the lower half of the engine has been dismantled, it is ESSENTIAL that the clutch spring retaining nut is correctly re-assembled so that the clutch shaft itself has an adequate amount of "end float." If this is not done, replacements will soon be necessary in the gearbox.

The clutch spring retaining nut should therefore be adjusted so that the effective width of the clutch assembly is between 3-665" and 3-680". This width is measured between the outer end of the large splines at the left-hand end of the clutch shaft, and the outer face of the lockwasher securing the nut at the other end.

### LUBRICATION OF ENGINE.

In order to maintain the efficiency of the engine and to reduce wear to a minimum it is essential that all moving parts are adequately lubricated. The system adopted for Villiers two-stroke engines is the PETROIL system in which a given quantity of oil is mixed with the petrol. As the mixture first enters the crankcase and then into the cylinder, all working parts are adequately lubricated, and as the amount of fuel used will increase with the power output, it will be seen that a greater quantity of oil is supplied under arduous conditions with wide throttle openings.

### ROUTINE ATTENTION AND DECARBONISING.

A summary of normal maintenance jobs and adjustments is given on page 10.

Full details regarding decarbonising will be found on page 50.

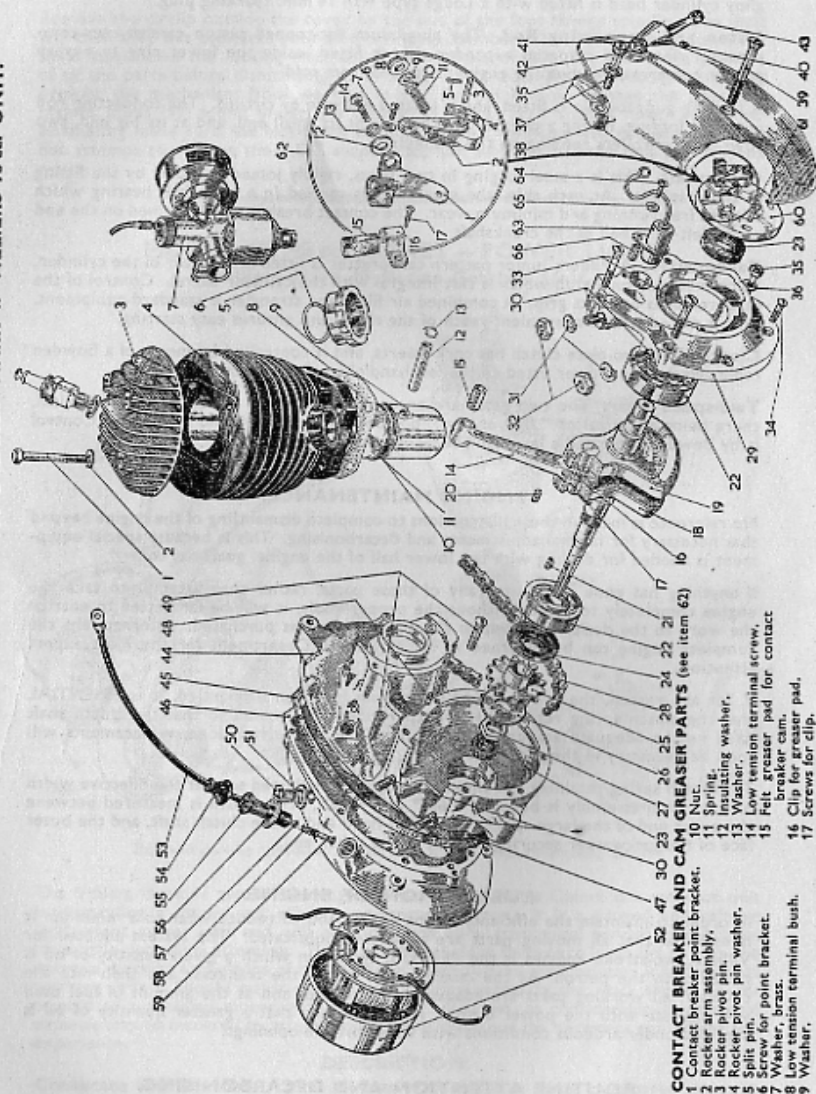

- CONTACT BREAKER AND CAM GREASER PARTS** (see item 62)  
 1 Contact breaker bracket.  
 2 Contact breaker assembly.  
 3 Rocker pivot pin.  
 4 Rocker pivot pin washer.  
 5 Split pin.  
 6 Screw for point bracket.  
 7 Washer, brass.  
 8 Low tension terminal bush.  
 9 Washer.  
 10 Nut.  
 11 Spring.  
 12 Insulating washer.  
 13 Washer.  
 14 Low tension terminal screw.  
 15 Felt greaser pad for contact breaker cam.  
 16 Clip for greaser pad.  
 17 Screws for clip.

**MODEL J11 98 cc. COMET.  
 ENGINE AND CONTACT BREAKER COMPONENTS.**

- |  |  |  |
|--|--|--|
| 1 Cylinder head bolt.  | 24 Gaco oil seal.                              | 48 Dowel in gearcase for crankcase door.   |
| 2 Washer.  | 25 Engine sprocket.                            | 49 Screw securing clutchcase to gearcase.  |
| 3 Cylinder head.   | 26 Lockwasher.                                 | 50 Oil filler plug.  |
| 4 Cylinder.  | 27 Nut.  | 51 Washer.   |
| 5 Exhaust nut washer.  | 28 Primary chain, 56 pitches, pre-stretched.   | 52 Flywheel assembly complete with leads. (See separate drawing for components.) |
| 6 Exhaust nut washer.  | 29 Crankcase door.                             | 53 High tension lead.  |
| 7 Carburettor complete with control and filter. (See separate drawing for components.) | — Crankcase door gasket.                       | 54 Rubber cover for terminal holder.   |
| 8 Cylinder base gasket.  | 30 Studs for cylinder base.                    | 55 High tension terminal holder.   |
| 9 Piston complete with bushes (standard size).   | 31 Spring washer.                              | 56 Felt washer.  |
| 10 Piston ring, standard size.   | 32 Nut.  | 57 Brass terminal screw.   |
| 11 Expander ring.  | 33 Screw for crankcase door.                   | 58 Brass terminal spring.  |
| 12 Gudgeon pin.  | 34 Screw for crankcase door.                   | 59 Terminal spring pad.  |
| 13 Circlip.  | 35 Crankcase drain plug and clutchbridge bolt. | 60 Adaptor for contact breaker.  |
| 14 Connecting rod, .001" over-size (bushed).   | 36 Washer, drain screw.                        | 61 Screw securing adaptor to crankcase door.                                     |
| 15 Small end bush.   | 37 Washer, plain.                              | — Gasket for adaptor.  |
| 16 Rollers for crankpin.   | 38 Cover, L.H. side.                           | 62 Contact breaker assembly and cam lubricator. (See page 40 for components.)    |
| 17 Crankpin, .001" oversize.   | 39 Screw for cover.                            | 63 Condenser.  |
| 18 Crankshaft, R.H.  | 40 Screw for cover.                            | 64 Screw securing condenser to crankcase door.                                   |
| 19 Crankshaft, L.H.  | 41 Clutch lever adjusting screw.               | 65 Washer.   |
| 20 Engine sprocket key.  | 42 Locknut.                                    | 66 Distance piece.   |
| 21 Flywheel key.   | 43 Clutch lever.                               |  |
| 22 Crankshaft ball bearing.  | 44 Gearcase.                                   |  |
| 23 Oil seal.   | 45 Clutchcase gasket.                          |  |
|  | 46 Clutchcase.                                 |  |
|  | 47 Dowels in gearcase and clutchcase.          |  |

**FLYWHEEL MAGNETO.**

The six-pole magneto provides current for both ignition and lighting purposes.

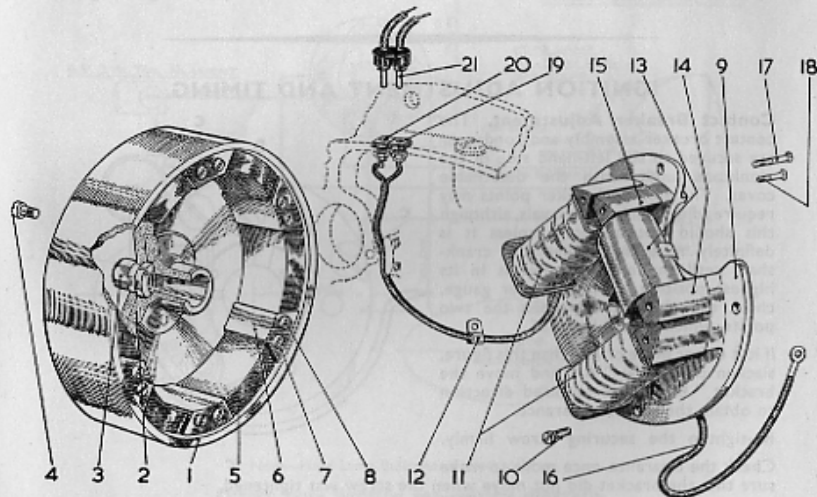

- |                            |   |  |
|----------------------------|---|--|
| 1 Flywheel.                | 10 Armature plate securing screws.                                      | 15 Ignition coil end, L.H.                           |
| 2 Flywheel centre.         | 11 Twin lighting coils complete with leads to sockets on engine casing. | 16 Low tension lead and shoe (rubber covered cable). |
| 3 Flywheel centre nut.     | 12 Clip securing lighting lead to armature plate.                       | 17 Screw for ignition and lighting coil ends.        |
| 4 Flywheel centre screws.  | 13 Ignition coil.   | 18 Screw for ignition coil ends.                     |
| 5 Flywheel magnets.        | 14 Ignition coil end, R.H.  | 19 Small socket for lighting lead.                   |
| 6 Flywheel pole pieces.    |   | 20 Large socket for lighting lead.                   |
| 7 Flywheel pole plates.    |   | 21 Twin plug for lighting lead.                      |
| 8 Flywheel pole screws.    |   |  |
| 9 Armature plate assembly. |   |  |

**Magneto Coils and Leads.** The ignition and lighting coils are carried on an armature plate secured to the engine clutchcase by four screws.

The high tension lead from the ignition coil to the sparking plug can be detached by unscrewing it from its socket on the top of the clutchcase.

When replacing it, be careful to ensure that the brass pad carried by the spring and secured to the terminal, makes contact with the soldered disc on the outside of the ignition coil.

The low tension lead from the ignition coil to the contact breaker passes through a passage-way provided in the gearcase and crankcase castings. At the ignition coil end it is soldered in place, and at the other end a shoe is fitted which is held in place by the low tension terminal screw. This screw also holds the condenser lead. If it is desired to remove the low tension lead from the engine, it must therefore be unsoldered from the ignition coil. If the coil and lead are to be taken out together, the shoe must be removed from the other end to allow the lead to pass through the castings.

The lighting leads are fastened to the lighting coils, and are led to two sockets on the clutchcase casting. If the leads have been taken out for any reason, they must be replaced so that they cannot touch the flywheel when the engine is running.

There is a clip on the armature plate, and a crevice in the clutchcase casting, and the lighting leads must be placed in these on re-assembly. (See assembly drawing on page 40).

**Model J11 98 cc. Comet Engine, right-hand side.** (Remove items marked "B" for access to Flywheel).

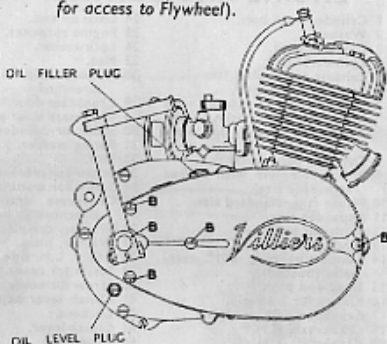

## IGNITION ADJUSTMENT AND TIMING.

**Contact Breaker Adjustment.** The contact breaker assembly and condenser are secured to the left-hand side of the crankcase, underneath the detachable cover. The contact breaker points may require adjustments at intervals, although this should not be done unless it is definitely necessary. Turn the crankshaft until the moving point is in its highest position. With a feeler gauge, check the clearance between the two points, which should be .015".

If it is either more or less than this figure, slacken the screw "A" and move the bracket "B" in the required direction to obtain the correct clearance.

Re-tighten the securing screw firmly.

Check the clearance once more to make sure that the bracket did not move when the screw was tightened.

**NOTE:** The feeler gauge should be a sliding fit between the contact breaker points. Never adjust the points so that the gauge is a tight fit; if this is done, proper clearance will not be obtained. When replacing the side cover, check that the clutch operating lever is replaced correctly, and that the clutch cable has the correct amount of slack (see page 45).

**Ignition Timing.** The contact breaker points should commence to open when the piston is  $\frac{1}{8}$ " before the top of its stroke.

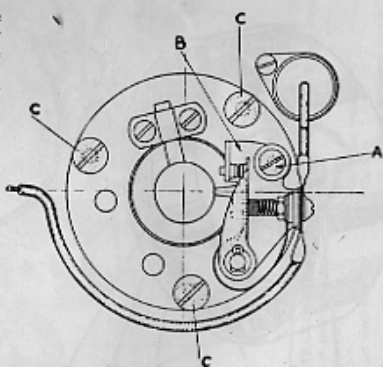

To check the timing, remove the cover on the left-hand side of the engine to expose the contact breaker mechanism, and also remove the sparking plug so that the top of the piston can be seen when setting it in its correct position.

After setting the piston, examine the contact breaker points, which should just be commencing to open. If they have not done so, or have opened fully, the timing is wrong. Correct as follows: Slacken the three screws "C" which secure the complete contact breaker assembly to the crankcase, and move the assembly to the left or right according to the adjustment required.

Turning the contact breaker plate to the right, or clockwise, will advance the ignition timing, and turning to the left, or anti-clockwise, will retard the timing.

When satisfied with the adjustment, re-tighten screws "C."

**NOTE:** Always set the contact breaker points to their correct gap of .015" before timing the magneto.

## DIRECT LIGHTING EQUIPMENT.

The lighting set fitted to the James 98 cc. Comet is a direct A.C. system, in which the current from the lighting coils is taken direct to the lamps by way of the headlamp switch. Provision is made in the toolbox for a dry battery (twin-cell pattern) to supply current for parking lights.

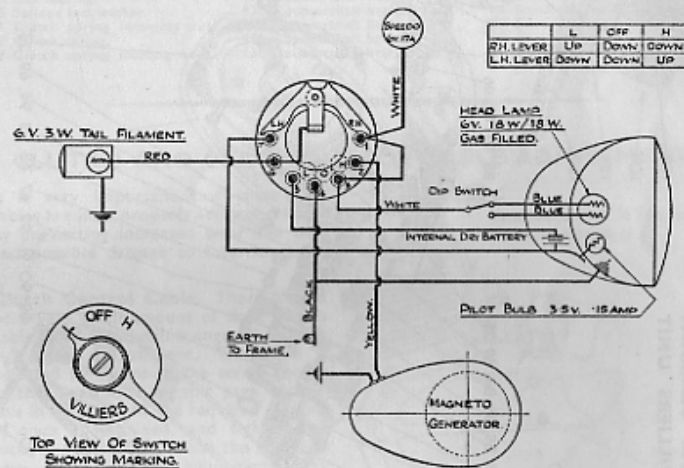

Note—Head Lamp Bulb should read 24/24 w.

Direct type lighting set—wiring diagram.

### Correct replacement bulbs.

Head lamp, main bulb ..	6 volt, twin filament, 24/24 watt B.C.
Head lamp, pilot bulb ..	3.5 volt, .15 amp., M.E.S.
Tail light bulb ..	6 volt, 3 watt M.B.C.

98 cc. COMET  
CLUTCH AND GEARBOX  
MARK 4F VILLIERS UNIT

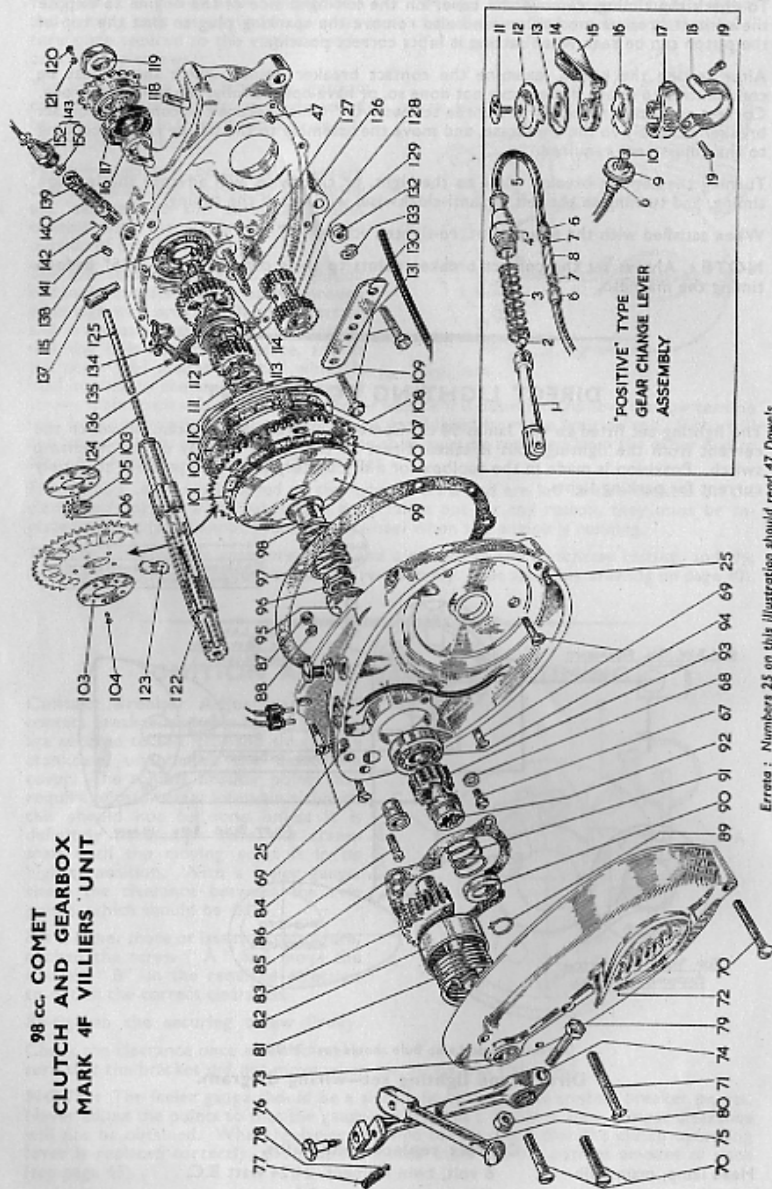

Errata: Numbers 25 on this illustration should read 47 Dowels

MODEL J11 98 cc. COMET ENGINE.  
CLUTCH AND GEARBOX ASSEMBLY COMPONENTS.

- |  |   |   |
|--|---|---|
| 67 Oil level plug.                               | 99 Outer clutch plate, R.H.                                 | 132 Nut.                                |
| 68 Washer.                                       | 100 Clutch sprocket with cork inserts.                      | 133 Spring washer.                      |
| 69 Screws securing clutchcase to gearcase.       | 101 Large clutch cork for clutch sprocket and corked plate. | 134 Gear selector lever.                |
| 70 Screws securing flywheel cover to clutchcase. | 102 Small clutch cork for clutch sprocket only.             | 135 Pivot pin, selector.                |
| 71 Screw securing flywheel cover to clutchcase.  | 103 Side plate for clutch sprocket ball bearing.            | 136 Gear operating plate.               |
| 72 Flywheel cover.                               | 104 Rivets for plate.                                       | 137 Spindle for selector lever.         |
| 73 Bush for kickstarter shaft.                   | 105 Ball race.  | 138 Stop pin for selector lever.        |
| 74 Kickstarter lever.                            | 106 Ball race.  | 139 Forked joint for gear selector.     |
| 75 Kickstarter pedal.                            | 107 Centre clutch plate, dished.                            | 140 Gear selector spring.               |
| 76 Kickstarter pedal pivot pin.                  | 108 Clutch plate, with cork inserts.                        | 141 Pin securing forked joint to lever. |
| 77 Kickstarter pedal spring.                     | 109 Outer clutch plate, L.H.                                | 142 Split pin for above.                |
| 78 Kickstarter pedal ball.                       | 110 Circlip.  |   |
| 79 Clamp bolt for kickstarter lever.             | 111 Splined washer, brass.                                  |   |
| 80 Nut.  | 112 Low gear wheel.   |   |
| 81 Kickstarter return spring.                    | 113 Sliding dog clutch.                                     |   |
| 82 Kickstarter return spring cover.              | 114 High gear wheel.  |   |
| 83 Kickstarter shaft.                            | 115 Ball bearing.   |   |
| 84 Bush in clutchcase for kickstarter shaft.     | 116 Distance piece.   |   |
| 85 Gasket, kickstarter cover.                    | 117 Oil seal.   |   |
| 86 Kickstarter stop pin.                         | 118 Driving sprocket.                                       |   |
| 87 Nut for stop pin.                             | 119 Retaining nut.  |   |
| 88 Spring washer.                                | 120 Locking screw for retaining nut.                        |   |
| 89 Circlip.                                      | 121 Spring washer.  |   |
| 90 Spring retaining washer.                      | 122 Clutch shaft.   |   |
| 91 Spring.                                       | 123 Clutch cotter.  |   |
| 92 Kickstarter ratchet.                          | 124 Clutch push rod, short.                                 |   |
| 93 Kickstarter pinion.                           | 125 Clutch push rod, long.                                  |   |
| 94 Ball bearing.                                 | 126 Countershaft spindle.                                   |   |
| 95 Splined lockwasher.                           | 127 Countershaft washer.                                    |   |
| 96 Clutch spring retaining nut.                  | 128 Countershaft bushed.                                    |   |
| 97 Clutch spring.                                | 129 Countershaft bush.                                      |   |
| 98 Clutch spring locating bush.                  | 130 Countershaft bridge.                                    |   |
|  | 131 Countershaft bridge bolt.                               |   |

GEAR CONTROL  
LEVER ASSEMBLY.

- 1 Forked joint, gear selector lever.
- 2 Cable nipple, engine end.
- 3 Gear selector spring.
- 4 Guide for forked joint.
- 5 Cable.
- 6 Adjusting screws.
- 7 Locknuts.
- 8 Cable adjusting sleeve.
- 9 Finger lock nut.
- 10 Cable nipple, control end.
- 11 Top screw.
- 12 Top cover.
- 13 Friction plate.
- 14 Trigger with spring.
- 15 Control lever.
- 16 Ratchet plate.
- 17 Control body.
- 18 Control clip.
- 19 Control screw.

CLUTCH AND GEAR CONTROL CABLE ADJUSTMENT.

It is very important that these two cables are kept properly adjusted, thereby preventing increased wear and tear and possible damage to internal parts.

**Clutch Control Cable.** There should be a very small amount of slack in this cable when the clutch is engaged; about  $\frac{1}{8}$ " to  $\frac{1}{4}$ " is sufficient. The cable is adjusted by means of the screw shown in the illustration on this page. Screw this in or out until the required amount of slack is obtained, and tighten the locknut afterwards. When the engine is new, fairly frequent adjustments may be necessary owing to the "bedding down" of the clutch surfaces. Insufficient slack movement in the clutch cable, or riding with one hand on the clutch lever, will cause the clutch to become slightly disengaged, resulting in its slipping instead of gripping firmly.

Always re-adjust the clutch cable after replacing the engine side cover, if this is removed to give access to the contact breaker.

**Gear Control Cable.** It is essential that the cable is always maintained in its correct adjustment, otherwise the gears will be seriously damaged, and it will be found that they will not remain in engagement.

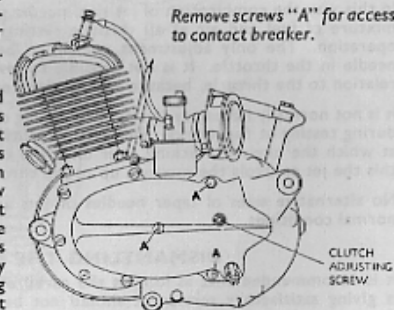

Remove screws "A" for access to contact breaker.

CLUTCH ADJUSTING SCREW



There must always be a slight amount of slack movement in the cable when the handlebar gear control lever is in the "HIGH" position,  $\frac{1}{16}$ " slackness being adequate; this ensures that the "HIGH" gear is fully engaged, a spring being used to retain the gears in "HIGH."

This cable has two adjusters, one about half-way between the control lever and the gearbox, and the other on the control lever itself. These will give a good range of adjustment.

The screw on top of the gear control lever must be kept tightened so that the lever is not loose, but has a smooth movement.

If the adjustments given above are correctly made, but low gear still jumps out of engagement, this indicates that the engine has been running with incorrect cable adjustments, thus damaging the gears.

**Gearbox Lubrication.** Remove the gearbox oil filler and oil level plugs (see engine diagram page 42). With the motorcycle on the stand, pour in recommended oil (SAE 140) until it starts to run out at the hole from which the oil level plug has been removed. Screw both plugs firmly into position.

### MODEL J11 98 cc. COMET — CARBURETTER.

The Villiers Junior carburetter, type 6/0, is used with the Mark 4F engine, and it should not normally be necessary to alter the setting obtained at the works after road-testing.

**Operation of the Carburetter.** The function of the carburetter is to supply a mixture of petrol and air in the correct proportions, no matter what the conditions under which the engine has to work. In the Villiers carburetter (see assembly drawings page 47) the float chamber and float surround the jet and centrepiece, the float rising as the fuel enters the chamber until the correct level is reached. At this point a forked lever which rests on top of the float, lifts a fuel needle valve to stop the fuel supply. Fuel enters the centrepiece through a hole in the side and passes through the calibrated jet fitted in the bottom of the centrepiece. The throttle is of a cylindrical pattern, and is fitted with a tapered needle which extends below it into the centrepiece. When the throttle, which is operated by a cable from the handlebar, closes the air supply, the largest diameter of the needle nearly closes the fuel outlet; but when the throttle is raised to admit more air, the smaller diameter of the needle allows more fuel to pass.

In this way the combination of jet size, needle position and needle taper gives a correct mixture of fuel and air at all throttle settings, making the carburetter automatic in operation. The only adjustment which can be made is to the position of the taper needle in the throttle. It is not possible to give a standard position for this needle in relation to the throttle, because each engine requires an individual adjustment.

It is not normally necessary to alter the setting of the needle, which has been determined during testing at the works. This setting controls the mixture strength from the point at which the engine is ticking over until the throttle is about two-thirds open. After this the jet controls the mixture up to full throttle position.

No alternative sizes of taper needles or jets are available, nor are they necessary for normal conditions.

### DISMANTLING THE CARBURETTER.

It is recommended that as long as the carburetter—or any other part of the engine—is giving satisfactory service, it should not be tampered with or taken to pieces. If dismantling becomes necessary, carry it out in the following way:

**To Remove Throttle from Body.** Open the throttle to its fullest extent, and unscrew the milled ring on top of the throttle body.

The throttle can now be withdrawn, but take care not to damage or bend the taper needle.

To detach the throttle from the cable, return the throttle control lever to the fully closed position, compress the throttle spring, and the inner cable can then be lifted out of its slot.

### JAMES MODEL J11 98 cc. COMET VILLIERS JUNIOR CARBURETTER TYPE 6/0

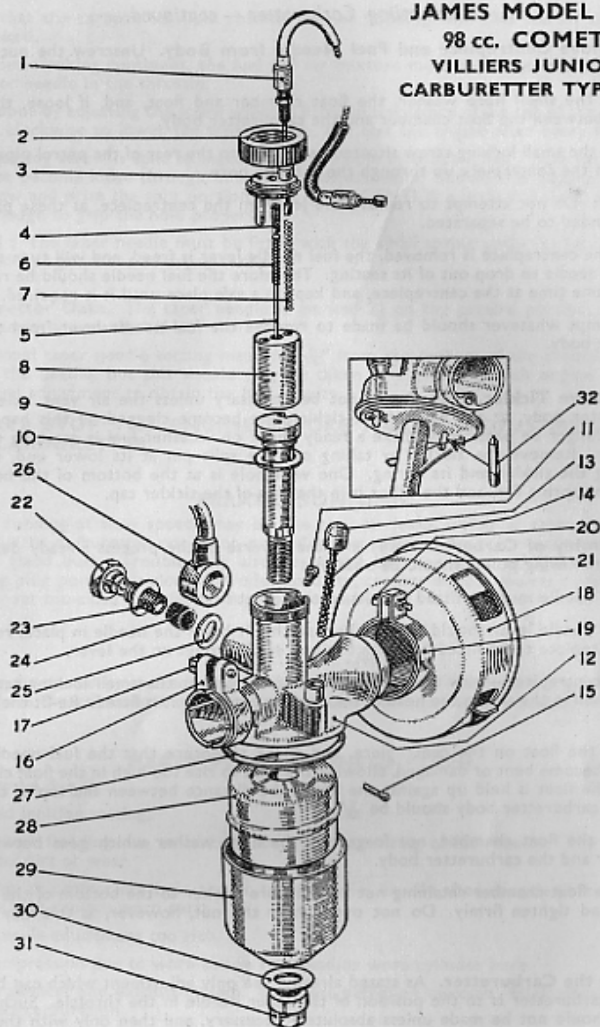

- |                                     |  |                             |
|-------------------------------------|--|-----------------------------|
| 1 Control cable complete.           | 12 Carburetter body, with fuel needle lever and bush.    | 22 Banjo union bolt.        |
| 2 Top ring.                         | 13 Tickler.  | 23 Washer, large hole.      |
| 3 Top disc with guide peg.          | 14 Tickler spring.                                       | 24 Gauze filter.            |
| 4 Adjuster for taper needle.        | 15 Tickler split pin.                                    | 25 Washer, small hole.      |
| 5 Taper needle, No. 24.             | 16 Clip securing carburetter to stub on cylinder barrel. | 26 Banjo union.             |
| 6 Taper needle spring.              | 17 Screw for clip.                                       | 27 Joint washer, float cup. |
| 7 Throttle spring.                  | 18 Air filter with clip.                                 | 28 Float.                   |
| 8 Throttle.                         | 19 Air filter clip.                                      | 29 Float cup.               |
| 9 Centrepiece with jet No. 1.120.   | 20 Bolt for clip.  | 30 Washer for bottom nut.   |
| 10 Fibre washer.                    | 21 Nut.  | 31 Bottom nut.              |
| 11 Locating screw for centre-piece. |  | 32 Fuel needle.             |

### Dismantling Carburetter — continued.

**To Remove Centrepiece and Fuel Needle from Body.** Unscrew the nut underneath the float chamber.

Remove the small fibre washer, the float chamber and float, and, if loose, the fibre washer between the float chamber and the carburetter body.

Remove the small locking screw situated below and to the rear of the petrol pipe union, and push the centrepiece up through the throttle bore.

**NOTE :** Do not attempt to remove the jet from the centrepiece, as these parts are not intended to be separated.

When the centrepiece is removed, the fuel needle lever is freed, and will turn to allow the fuel needle to drop out of its seating. Therefore the fuel needle should be removed at the same time as the centrepiece, and kept in a safe place until it is required.

No attempt whatever should be made to remove the fuel needle lever from the carburetter body.

**To Remove Tickler.** This should not be necessary unless the air vent hole in the carburetter body, at the base of the tickler, has become clogged. If this happens, it will no longer be possible to make a ready check on whether fuel is reaching the carburetter. Remove the tickler by taking out the split pin at its lower end, thereby releasing the tickler and its spring. One vent hole is at the bottom of the hole into which the spring fits, and the other is in the side of the tickler cap.

**Re-assembly of Carburetter.** This is the reverse of the process already described, but the following points should be observed :

The fuel needle must be fitted into its seating point first.

The fuel needle lever should then be held so that it holds the needle in place, ready for the centrepiece to be fitted between the two small prongs on the lever.

Fit the centrepiece—with the fibre washer first—so that the small locking screw can locate itself in the slot in the head of the centrepiece when it is fitted. Re-fit the locking screw.

Replace the float on the centrepiece, and check to ensure that the fuel needle lever has not become bent or damaged, allowing the float to rise too high in the float chamber. When the float is held up against the lever, the distance between the top of the float and the carburetter body should be  $\frac{1}{16}$ ".

Replace the float chamber, not forgetting the fibre washer which goes between the chamber and the carburetter body.

Refit the float chamber retaining nut and its fibre washer to the bottom of the centre-piece, and tighten firmly. Do not overtighten the nut, however, as this may distort the jet.

**Setting the Carburetter.** As stated already, the only adjustment which can be made to the carburetter is to the position of the taper needle in the throttle. Such adjustments should not be made unless absolutely necessary, and then only with the use of care and patience, making several small adjustments to find the best position, in preference to a single large alteration.

In this way the best possible setting can be found with the least amount of trouble.

The best setting of the taper needle is that which gives the most even two-stroking when the engine has attained its usual running temperature and is running at normal loads and speeds.

If the engine four-strokes when pulling very hard, this indicates that the mixture of fuel and air passing to the engine is too rich. As this can cause the sparking plug to oil up and stop the engine, the condition should be corrected at once.

Check that the carburetter float chamber is not flooding, and that the air cleaner is not choked.

If the four-stroking continues, the fuel and air mixture must be weakened by lowering the taper needle in the throttle.

This is done by adjusting the screw which is fitted in the centre of the top of the throttle. Turn it clockwise to lower the taper needle, and test the engine after every half-turn.

The adjusting screw is split to make it grip the hole in which it fits ; take care that it does not become loose through unnecessary adjustments. Should this happen, remove the screw and prise the split portion apart VERY GENTLY, a little at a time, until it is tight enough to grip the hole properly.

**NOTE :** The taper needle must be fitted with the small spring under its head, so that it is held up against the adjusting screw.

**Carburetter Data.** The taper needle is marked  $2\frac{1}{2}$  on the parallel portion. Centre-piece and jet are marked J120.

The normal taper needle setting measures  $\frac{3}{16}$ " from the bottom of the throttle to the end of the needle, but this should only be taken as a guide, as each engine requires individual adjustment to obtain the best results.

**ALWAYS STOP THE ENGINE BEFORE MAKING ADJUSTMENTS TO THE CARBURETTER.**

### ERRATIC RUNNING.

Erratic running at slow speeds may be due to : air leaks, either at carburetter stub joint, due to carburetter not being pushed home, cylinder base joint, crankcase joint face or gland bush. Trouble may also be caused by over advanced ignition setting, sparking plug points too close, corroded or dirty, contact breaker points dirty, pitted, loose or set too close or defective high tension-wire.

### WEAK MIXTURE.

This may be caused by choked gauzes in fuel supply system. After considerable mileage, wear of the throttle slide and/or carburetter body may cause weak mixture.

### HEAVY PETROL CONSUMPTION.

This may be due to :

Retarded ignition setting.

Carburetter flooding due to leaking float, or bad seating of fuel needle. This may be caused by dirt or wear.

Worn jet or centrepiece hole and/or taper needle, usually after considerable mileage. Remedy is to replace worn parts.

Taper needle adjustment too rich.

Poor compression due to worn piston rings and/or worn cylinder bore.

Choked silencer and exhaust system. Incorrect petrol-oil mixture. High altitudes may also affect carburation.

### CARBURETTER CABLE ADJUSTMENT.

A certain amount of slack may develop in the throttle cable after a time ; this can be taken up by means of the adjuster on top of the carburetter.

### AIR CLEANER.

The air cleaner should be removed for cleaning approximately every 2,000 miles. Remove by releasing clip, dip the cleaner in petrol and after drying, immerse in thin oil and hang up to drain before refitting to carburetter.

## CADET AND COMET — DECARBONISING.

We do not specify any particular mileage at which to carry out the task of decarbonisation as the rate at which carbon forms is largely dependent upon the way the rider treats his machine and also the type of riding it is used for. Carbon tends to form more quickly if a machine is used for short journeys than on long runs, when the engine becomes really warm and will blow out most of the carbon. Hence, while one machine may require attention at 2,000 miles another might have accumulated only a slight deposit at 5,000 miles. Irrespective of mileage, it will be time to decarbonise when excessive pinking is heard.

### SEQUENCE OF OPERATIONS FOR DECARBONISING.

Remove H.T. lead from sparking plug, disconnect fuel pipe from tank, remove carburetter and exhaust pipe nut from cylinder.

Slacken cylinder head bolts, a quarter of a turn at a time, working diagonally, remove bolts and lift cylinder head.

Slacken and remove cylinder base nuts and spring washers, working diagonally as for head. Position piston at bottom of stroke.

Lift cylinder in one steady movement: do not twist or piston rings may be trapped in the ports.

Remove piston by extracting circlips with thin nosed pliers. Tap gudgeon pin out gently, holding piston so that no shock is transmitted to the connecting rod. It is not necessary to remove gudgeon pin completely.

Remove carbon deposit from cylinder head by careful and gentle scraping with a piece of copper strip or stick of solder sharpened to "screwdriver" shape. Avoid using a steel instrument as this is likely to score the alloy.

Carbon will form around the edges of the exhaust port and may, if neglected, constrict the orifice and hinder the passage of gases. Remove by chipping with aforementioned tool, taking care not to damage the bore.

The piston may be cleaned in the same way as the cylinder head and the top rubbed gently to remove all trace of carbon. The correct way to replace it is with the top piston ring peg to the front. The piston rings may be removed without risk of damage by introducing three pieces of thin metal strip spaced round the piston (see illustration) and then sliding off the ring. Do not scratch the piston. It is desirable to ensure that each ring is refitted in its original groove.

If piston rings are cracked or show brown patches denoting gas leakage—replace with new ones.

When re-assembling, fit piston in same manner as it was removed. REFIT CIRCLIPS.

Make sure all faced joints are clean and free from grit when re-building. Always fit new jointing washers. There is no gasket at cylinder head of 98 cc. engines.

Smear cylinder wall with oil, slide cylinder over the rings with piston at bottom of stroke by pressing side of ring opposite peg into slot and canting cylinder over to retain ring. Press in ring on either side of peg and swivel cylinder gently to and fro gradually lowering over ring. Repeat for lower ring.

Tighten cylinder base nuts and cylinder head bolts evenly a quarter of a turn at a time and working diagonally. Remember to fit spring washers under base nuts.



## TRACING ENGINE TROUBLES.

For the satisfactory running of two-stroke engines it is essential that three main conditions are fulfilled, and by making a systematic and intelligent investigation the faults can usually be located. If the engine stops, symptoms will generally give a clue to the cause, but where this is not the case, the trouble can be more easily traced by following a definite method of investigation. The three conditions mentioned above are as follows:

(1) The required quantity of petrol-and-air mixture must enter the engine, which means that a proper supply of fuel has to be available from the carburetter, and that the throttle should open and close freely.

(2) The sparking plug must give a good spark, at the right time in relation to the position of the piston on its upward stroke.

(3) The engine must be in good mechanical condition, with no air leaks at the various joints.

There must also be efficient compression of the air in the cylinder and crankcase. This can be easily checked by putting the gearbox into neutral position, and rotating the crankshaft by means of the kickstarter. On every revolution a definite resistance should be felt, caused by the air in the cylinder being compressed.

**Making a Preliminary Check.** When the cause of the trouble is not evident, carry out a preliminary check covering the following points; if this fails to trace the cause reference should be made to the Fault Finding Chart (pages 52 and 53).

Having made sure that there is "petrol" in the tank, and that the tap is in the "on" position, depress the tickler on the carburetter to ensure that there is no blockage in the fuel supply, either in the tap, fuel pipe, banjo union or fuel needle seating. If the fuel supply is clear, fuel will spurt from the vent hole in the side of the tickler cap. Examine the throttle twist grip control to make certain that the throttle is actually opening when the twist grip is moved.

Being satisfied that fuel is reaching the carburetter, next unscrew the sparking plug, and with the high tension lead still attached, lay the plug on the cylinder head. Turn the engine by means of the kickstarter, and if there is a good spark, it is possible that the ignition timing is incorrect.

## MAJOR REPAIRS

The contents of this booklet are intended to give the owner a working knowledge of his machine and to enable him to carry out normal adjustments, maintenance and simple repairs. Where major repairs are concerned, we strongly advise the amateur mechanic to leave well alone and entrust difficult jobs, should they ever arise, to a qualified mechanic or ourselves. Splitting the crankcase halves, for instance, is a very difficult matter and demands great skill and care, while years of experience are needed to replace a big end assembly and true the shafts. Our Repairs Department is fully equipped and major repairs carry a full three months' guarantee. With these facilities at the disposal of James owners, we feel that it will repay our customers not to attempt too much but to keep within the limits outlined in this book.

## FAULT FINDING CHART.

Sequence of Testing.	Possible Trouble.	Remedy.
<b>Engine will not start.</b>		
Depress tickler on carburetter to check whether fuel is reaching carburetter.	No fuel reaching carburetter, air lock in petrol pipe.	Turn tap to ON, refill tank, clear air vent in filler cap.
If no fuel, even when tap is on and fuel is in tank.	Choked petrol pipe, filter on tap, filter in banjo. Fuel needle sticking in seating.	Remove and clean out. Disassemble carburetter and fit new needle.
Test for spark by holding sparking plug body on cylinder head.	Leak along insulation of plug or high tension lead.	Try a new plug of the type recommended and/or new H.T. lead.
If still no spark: Test for spark at end of H.T. lead held $\frac{1}{4}$ " from cylinder fins.	Plug points may be oily or sooted up. If no spark at end of H.T. lead, contact breaker point gap may be too narrow or points pitted or dirty or oily.	Clean plug or fit new one. Adjust point gap to ".015". Clean.
	Moisture on insulation of condenser.	Clean and dry out.
	High tension terminal not making good contact on ignition coil.	Clean and correct.
	Cracked insulation of adjustable contact breaker point.	Replace.
	Damaged insulating sleeving on wires connecting contact breaker to coil or condenser.	Replace with new sleeving.
	Faulty connection to low tension wire of ignition coil.	Correct.
	Faulty condenser.	Replace.
	Faulty ignition coil.	Replace.
If above tests are satisfactory but engine will not start.	Mixture may be too rich due to use of strangler, or incorrect setting of taper needle.	Open throttle wide and depress kickstarter several times to clear engine of petrol, drain crankcase.
	Air leaks at carburetter stub or manifold joint causing weak mixture.	Tighten joints evenly.
	Incorrect ignition timing.	Check, following instructions given.

## FAULT FINDING CHART — (continued)

Sequence of Testing.	Possible Trouble.	Remedy.
<b>Engine Four or Eight Strokes</b>		
Strangler may not be fully open or taper needle in a too high position. Air filter may need cleaning.	Mixture too rich.	Lower taper needle by moving to a WEAKER position. Lower needle by adjuster screw fitted in throttle.
Check by watching for excessive smoke from exhaust pipe or silencer.	Engine may four stroke for a little while after standing due to accumulation of oil in crankcase.	Usually ceases when engine has been running for a few minutes unless too much oil has been mixed with the petrol.
	Flooding of carburetter.	Persistent flooding is usually due to dirt under fuel needle seating, or sticking fuel needle, damaged seating or punctured float.
<b>Engine Lacks Power.</b>		
	Engine out of tune, bearings worn. Unsuitable sparking plug.	Overhaul. Replace with recommended type.
	Loss of compression.	Tighten cylinder head bolts. Replace worn piston rings.
	Incorrect "petrol" mixture.	Correct mixture is 1 part oil, 20 parts petrol.
	Excessive carbon deposit on piston crown and cylinder head.	Decarbonise.
	Exhaust system choked with carbon.	Clean out silencer and exhaust pipes.
	Incorrect carburetter setting.	Check and adjust.
	Air cleaner choked.	Wash in petrol, drain and dip in thin oil.
	Obstruction in fuel supply.	Clean out tap, fuel pipe and filters.
	Incorrect ignition timing.	Check and adjust.
	Brakes binding.	Adjust.
	Driving chains too tight.	Adjust.
<b>Engine will not run Slowly.</b>		
	Weak mixture due to air leaks at carburetter stub or manifold joint, crankcase and cylinder base joints.	Tighten all joints evenly.
	Crankcase drain screw loose or missing.	Tighten or replace.
	Worn crankshaft bearings or leaking seal.	Replace.
	Ignition timing too far advanced.	Correct.
<b>Engine Suddenly Stops Firing.</b>		
	Sparking plug lead detached.	Replace.
	Plug points bridged by oil, carbon, or deposit caused by use of leaded petrol.	Clean or replace.
	Short circuit of high tension lead to frame possibly by water on H.T. lead.	Insulate. If wet, dry out.

## 98 cc. MODEL J11 COMET

### TECHNICAL DATA

Engine	Villiers Mk. 4F two-stroke unit.
Cubic Capacity	98 cc. (6 cu. ins.).
Stroke	57 mm. (2.244").
Bore	47 mm. (1.8504").
Compression Ratio	8 : 1.
Approx. Brake Horse Power	2.8 B.H.P. at 4000 R.P.M.
Ignition Timing	Points commence to open $\frac{1}{8}$ " before top dead centre
Contact Breaker Gap	.015" maximum separation.
Sparkling Plug Type	Lodge H14. 14 mm. short reach.
Sparkling Plug Gap	.018"/.025".
Correct Lamp Bulbs	Head main : 6 volt, 24/24 watt B.C. (A.C. direct lighting set) Head pilot : 3.5 volt, .15 amp., M.E.S. Tail : 6 volt, 3 watt M.B.C.
Carburetter	Type : Villiers "Junior" type 6/0. Jet size : No. J120. Needle : No. 2 $\frac{1}{2}$ type 6/0.
Sprockets	Engine : 17 teeth. Clutch : 42 teeth. Final drive : 14 teeth. Rear : 48 teeth.
Chains	Primary : $\frac{3}{8}$ " x $\frac{1}{4}$ " x .225" endless pre-stretched. 56 pitches. Rear : $\frac{1}{2}$ " x .305" x .192". 118 pitches.
Chain Adjustment	Primary : $\frac{1}{8}$ " whip at tightest point. Rear : $\frac{1}{8}$ " to $\frac{1}{4}$ " whip at tightest point.
Gearbox Ratios	1-64 : 1 and 1 : 1.
Overall Gear Ratios	First : 13-1 and 1 : 1. Top : 8-5 : 1.
Engine Bearings	Ballraces (2) 25 x 52 x 15 mm.
Big End Bearing	Roller (28) .1876"/.1874" dia. x .1877"/.1873" long.
Hub Bearings	Front cup and cone : 20 balls $\frac{1}{8}$ " dia. Rear journal : 15 x 42 x 13 mm. Skofko 6302.
Steering Head Bearings	Ball : top 21 balls $\frac{1}{8}$ " dia. bottom 21 balls $\frac{3}{16}$ " dia.
Wheel Rim Sizes	Front and rear : WMO 19.
Tyre Sizes	Front and rear : 2.25" x 19".
Tyre Pressures—Normal	Front : 19 lbs. Rear : 29 lbs.
Spokes	Front L.H. side (18) : $7\frac{1}{2}$ " x 12 swg. Front R.H. side (18) : $7\frac{1}{2}$ " x 12 swg. Nipples (36) : .225" x 12 swg. Rear L.H. side (18) : $7\frac{1}{2}$ " x 10 swg. Rear R.H. side (18) : $7\frac{1}{2}$ " x 10 swg. Nipples (36) : .225" x 10 swg.

Brake Drum Diameters	Front : 4" (10.15 cm.). Rear : 5" (12.7 cm.).
Total Braking Area	11 $\frac{3}{4}$ " (76 cm <sup>2</sup> ).
Fuel Tank Capacity	2 Imperial gallons (9 litres).
Fuel Mixture	One part recommended oil to 20 parts petrol. ( $\frac{1}{2}$ pint oil to one gallon petrol or 4 filler cap measures to one gallon petrol).
Oil Capacity of Chaincase and Gearbox	Approx. $\frac{1}{2}$ pint. Fill to oil level plug.
Wheelbase	49" (124.5 cm.).
Saddle Height	27 $\frac{1}{2}$ " (70 cm.).
Ground Clearance	4 $\frac{1}{2}$ " (12 cm.).
Width Over Bars	25 $\frac{1}{2}$ " (65 cm.).
Overall Length	78" (198 cm.).
Approx. Weight	138 lbs.

## 150 cc. MODEL J15 CADET

### TECHNICAL DATA

Engine	Villiers Mk. 30C two-stroke unit.
Cubic Capacity	147 cc. (9.0 cu. ins.).
Stroke	62 mm. (2.440").
Bore	55 mm. (2.167").
Compression Ratio	8.3 to 1.
Approx. Brake Horse Power	5.43 B.H.P. at 4-250 R.P.M.
Ignition Timing	$\frac{3}{8}$ " before T.D.C.
Contact Breaker Gap	.015" maximum.
Sparkling Plug Type	Lodge H14 (14 mm.).
Sparkling Plug Gap	.018"/.025".
Correct Lamp Bulbs	Head main : 6 volt—30/30 watt, S.B.C. Pre-focussed. (Direct lighting set) Head pilot : 3 $\frac{1}{2}$ volt—15 amp., M.B.C. Tail : 6 volt—3 watt, M.B.C. Speedo : 6 volt—17 amp., M.B.C.
(Rectifier lighting set)	Head main : 6 volt—24/30 watt. Head pilot : 6 volt—3 watt, M.B.C. Tail : 6 volt—3 watt, M.B.C. Tail-Stoplight : 6 volt—18/3 watt, B.C. (if fitted) Speedo : 6 volt—17 amp., M.B.C.
Battery	Lucas type—PUZ7E-9, 6 volt, 12 amp.-hours.
Carburetter	Type : Villiers S.19 single lever. Size of main jet : No. 80. Carburetter needle : No. 3 $\frac{1}{2}$ . Normal needle setting : 2.015" out.

<b>Sprockets</b>	Engine : 23 teeth. Clutch : 51 teeth. Gearbox : 15 teeth. Rear : 44 teeth.
<b>Chains</b>	Primary : $\frac{3}{8}$ " x $\frac{1}{4}$ " x .225" endless pre-stretched. 66 pitches. Rear : $\frac{3}{8}$ " x .335" x .205". 116 pitches.
<b>Chain Adjustment</b>	Primary : $\frac{1}{8}$ " whip. Rear : $\frac{3}{8}$ " to $\frac{1}{2}$ " whip.
<b>Gearbox Ratios</b>	1, 1-34, 2-55 to 1.
<b>Overall Gear Ratios</b>	Bottom : 16-6. Second : 8-7. Top : 6-5.
<b>Engine Bearings</b>	Ballraces (3) : 20 x 47 x 14 mm.
<b>Big End Bearings</b>	Rollers : $\frac{1}{4}$ " dia. x $\frac{1}{4}$ " long (12 steel, 6 bronze) $\frac{1}{4}$ " dia. x $\frac{1}{2}$ " long.
<b>Hub Bearings</b>	Front Cup and Cone : 20 balls $\frac{1}{8}$ " dia. Rear Journal : 15 x 42 x 13 mm. S SKF 6302.
<b>Steering Head Bearings</b>	Top : 21 balls $\frac{3}{16}$ " dia. Bottom : 21 balls $\frac{3}{16}$ " dia.
<b>Wheel Rim Sizes</b>	Front and Rear : WMO 19.
<b>Tyre Sizes</b>	Front and rear : 2.75" x 19".
<b>Tyre Pressures—Normal</b>	Front 15 lbs. Rear 22 lbs.
<b>Spokes</b>	Front L.H. side (18) : $7\frac{1}{2}$ " x 12 swg. Front R.H. side (18) : $7\frac{1}{2}$ " x 12 swg. Nipples—front (36) : .225" x 12 swg. Rear L.H. side (18) : $7\frac{1}{2}$ " x 10 swg. Rear R.H. side (18) : $7\frac{1}{2}$ " x 10 swg. Nipples—rear (36) : .225" x 10 swg.
<b>Brake Drum Diameter</b>	Front 4" (10-15 cm.). Rear 5" (12-7 cm.).
<b>Total Braking Area</b>	11 $\frac{3}{4}$ sq. ins. (76 cm <sup>2</sup> ).
<b>Fuel Tank Capacity</b>	2 Imperial gallons (9 litres).
<b>Fuel Mixture</b>	One part recommended oil to 20 parts petrol. (4 filler cap measures of oil to one gallon petrol).
<b>Oil Capacity of Gearbox</b>	Approx. $\frac{1}{2}$ pint. Fill to oil level mark on dipstick.
<b>Oil Capacity of Primary Case</b>	Approx. $\frac{1}{4}$ pint. Fill to oil level plug.
<b>Speedometer</b>	Smiths 80 m.p.h. or 140 k.p.h. magnetic type, illuminated.
<b>Speedometer Cable</b>	Rear wheel drive, length 4' 8".
<b>Wheelbase</b>	49" (124-5 cm.).
<b>Saddle Height</b>	29" (73-7 cm.).
<b>Ground Clearance</b>	5" (12-7 cm.).
<b>Width Over Bars</b>	26" (65 cm.).
<b>Overall Length</b>	78" (198 cm.).
<b>Approx. Weight</b>	170 lbs.

## GUARANTEE

We give the following guarantee with our motor cycles, motor cycle combinations and sidecars, including all accessories and component parts other than tyres, saddles, chains and lighting and electrical equipment, and other than accessories and component parts supplied to the order of the Purchaser and differing from those comprised in the standard specifications supplied with our motor cycles, motor cycle combinations and sidecars, but including accessories and parts supplied by way of exchange as hereinafter provided. This guarantee is given in place of any implied conditions or warranties or any liabilities whatsoever statutory or otherwise; no guarantee except that hereinafter contained and no conditions or warranty whatsoever statutory or otherwise is given or is to be implied, nor are we to be under any liability whatsoever except under the guarantee hereinafter contained. Any statement, description, condition or representation contained in any catalogue, advertisement, leaflet or other publication shall not be construed as enlarging, varying or overriding anything herein contained. In the case of machines (a) which have been used for "hiring out" purposes or (b) any motor cycle and/or sidecar used for any dirt track, cinder track or grass track racing or competitions (or any competition of any kind within an enclosure for which a charge is made for admission to take part in or view the competition) or (c) machines from which the trade mark, name or manufacturing number has been altered or removed or (d) any machines in which parts have been used not supplied by or approved by the motor cycle manufacturer or (e) any machine from which the silencing system as fitted by the manufacturer has been partially or wholly removed or interfered with, no guarantee, condition or warranty of any kind statutory or otherwise, is given or is to be implied, nor are we to be under any liability whatsoever in respect of any such machine. We guarantee, subject to the conditions mentioned below, that all precautions which are usual and reasonable have been taken by us to secure excellence of materials and workmanship, but this guarantee is to extend and be in force for six months only in U.K. and ninety days overseas from date of purchase, or date of exchange in case of any accessory or part supplied by way of exchange as hereinafter provided, and damages for which we make ourselves responsible under this guarantee are limited to the free repair of or supply of a new part or accessory in exchange for the part of the motor cycle, motor cycle combination or sidecar or accessory which may have proved defective. We undertake, subject to the conditions mentioned below, to make good in manner aforesaid any part or accessory covered by this guarantee which has proved defective within the said period. We do not undertake to replace or refix or bear the cost of replacing or refixing any such new part or accessory in the motor cycle, motor cycle combination or sidecar. As motor cycles, motor cycle combinations and sidecars are easily liable to derangement by neglect or misuse, this guarantee does not apply to defects caused by wear and tear, misuse or neglect.

The term "misuse" shall include, amongst others, the following acts :

1. The attaching of a sidecar to a motor cycle in such a manner as to cause damage or calculated to render the latter unsafe when ridden.
2. The use of a motor cycle or of a motor cycle and sidecar combined, when carrying more persons or a greater weight than for which the machine was designed by the manufacturers.
3. The attaching of a sidecar to a motor cycle by any form of attachment not provided, supplied or approved by the manufacturers, or to a motor cycle which is not designed for such use.

We do not guarantee tyres, saddles, chains or lighting and electrical equipment, or any accessories or component parts supplied to the order of the Purchaser differing from those comprised in the standard specifications supplied with our motor cycles, motor cycle combinations or sidecars. As regards all such tyres, saddles, chains, lighting and electrical equipment, accessories and component parts, no guarantee, condition or warranty of any kind statutory or otherwise is given or is to be implied, and we are to be under no liability whatsoever in respect thereof.

**CONDITIONS OF GUARANTEE**—If a defective part or accessory should be found in our motor cycles, motor cycle combinations or sidecars, or in any part or accessory supplied by way of exchange as before provided, it must be sent to us CARRIAGE PAID and accompanied by an intimation from the owner that he desires to have it repaired or exchanged free of charge under our guarantee, and he must also furnish us at the same time with the frame number of the machine, the date of purchase or the date when the alleged defective part or accessory was exchanged as the case may be.

Failing compliance with the above, such articles will lie here at **THE RISK OF THE OWNER**, and this guarantee and any implied guarantee, warranty or condition shall not be enforceable.

**REPAIRS**—Any motor cycle, motor cycle combination or sidecar sent to us to be plated, enamelled or repaired will be repaired upon the following conditions, *i.e.*, we guarantee that all precautions which are usual and reasonable have been taken by us to secure excellence of materials and workmanship, such guarantee to extend and be in force for three months only from the time such work shall have been executed, and this guarantee is in lieu and in exclusion of all conditions and warranties statutory or otherwise, and all liabilities whatsoever and the damages recoverable are limited to the cost of any further work which may be necessary to amend and make good the work found to be defective.

**NOTE**—We do not appoint agents for the sale on our behalf of our motor cycles or other goods, but we assign to motor cycle Dealers areas in which we supply to such Dealers exclusively for re-sale in such areas. No such Dealer is authorised to transact any business, give any warranty, make any representation or incur any liability on our behalf. Published retail prices are for delivery free of charge at Dealers' premises. All goods are offered for sale subject to the price ruling at the time of delivery. All prices and specifications are subject to alteration without notice.



*Money Saving Motorcycles*

James Publication No. 1511 / 55 / 2-5M  
Reprinted, September, 1955

PRINTED IN ENGLAND