



**1955  
MODEL K12**

**SPARE PARTS LIST**

**225 cc  
COLONEL**

MANUFACTURERS-

JAMES MOTOR CYCLES LTD · GREET · BIRMINGHAM · II

Price:-TWO SHILLINGS

# **JAMES**

## **Spare Parts for 1955 Colonel 225 cc Model K 12**

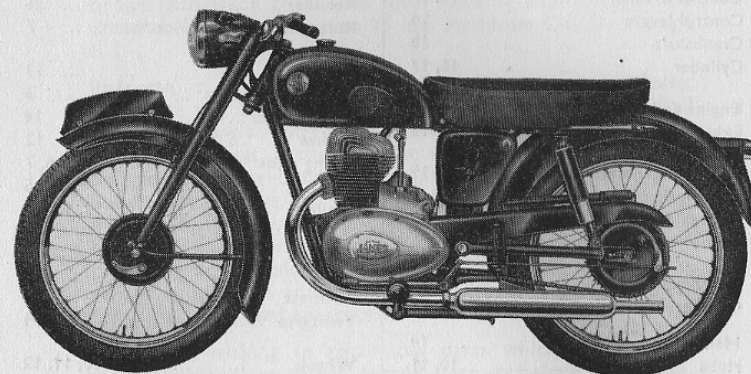

### **IMPORTANT**

With the exception of certain proprietary components, prices listed herein are increased by 5% as from 14th April, 1955.

FIRST FRAME NUMBER IN SERIES : 55 K 12/55

**JAMES MOTOR CYCLES LIMITED**  
**GREET : BIRMINGHAM, 11 : ENGLAND**

Telephone: VICTORIA 2211 (5 lines)    Telegrams: MOCYCLE, BIRMINGHAM

Nearest Railway Station: Birmingham, Small Heath, B.R. Western Region

**CONTENTS.**

Additional equipment ... .. 27	Ignition coil ... .. 19
Battery case ... .. 13	Lighting equipment ... .. 26
Brakes ... .. 10, 11	Mudguard, front ... .. 12
Bulbs ... .. 26	Mudguard, rear ... .. 13
Carburetter ... .. 21, 22	Petrol tank ... .. 12
Chain, rear ... .. 14	Piston ... .. 18
Chainguard ... .. 13	Rectifier ... .. 26
Clutch... .. 20	Rotary Exchange Service ... .. 7
Contact Breaker ... .. 16, 17	Silencer ... .. 13
Control levers ... .. 14	Spares and Repairs ... .. 3
Crankshaft ... .. 18	Speedometer ... .. 14
Cylinder ... .. 16, 17	Spokes ... .. 12
Engine and contact breaker 15, 16, 17	Spring units ... .. 6, 7
Exhaust system ... .. 13	Stand ... .. 4, 5
Flywheel generator ... .. 18, 19	Sundries ... .. 12, 13, 14
Front fork ... .. 8, 9	Toolbox ... .. 13
Footrests ... .. 5	Tools ... .. 13
Frame ... .. 4, 5	Twinseat ... .. 13
Gearbox, ... .. 23, 24, 25	Twistgrip ... .. 14
Guarantee ... .. 28	Wheels ... .. 10, 11, 12
Handlebar ... .. 14	
Hubs ... .. 10, 11	

**ILLUSTRATIONS.**

Colonel ... .. 1
Carburetter ... .. 21
Clutch ... .. 20
Crankshaft and piston ... .. 18
Engine and contact breaker ... .. 16
Flywheel generator ... .. 19
Frame ... .. 4
Front fork ... .. 8
Gearbox, 4 speed ... .. 23
Hub, front ... .. 10
Hub, rear ... .. 11
Ignition coil ... .. 19
Spring unit ... .. 6

## Spares and Repairs

Genuine James spare parts are obtainable from James Dealers almost everywhere. The name of the nearest stockist will be gladly forwarded on receipt of a stamped addressed envelope.

If a James Dealer cannot supply from stock, he will order specially. We can only supply direct in emergency or where no James Dealer is at hand. In such circumstances, please quote James Part Number (or enclose pattern), together with full frame and engine numbers. Unless money is sent to cover order, (add 1/- in the £1 to cover packing and postage), we despatch C.O.D. post up to 15 lbs. Minimum C.O.D. postage is 2/-.

Instructions regarding repairs should be clear and definite, otherwise the cost may be greater than expected. We shall be pleased to give estimates for repairs if parts are sent to us for that purpose. If the estimate is accepted, no charge will be made for the preliminary examination, but should the owner decide not to have the work carried out, a nominal charge may be made to cover the cost of whatever work may have been done to prepare the estimate. Parts sent to us as patterns or for repairs, should have attached to them a label with the sender's full name and address. Instructions regarding such parts should be sent separately.

Customers wishing to retain old parts which are replaced during overhaul or repair, should state so before work commences, as normally such parts are scrapped upon removal.

If it is necessary to bring a machine, or parts, to the works for an urgent repair, it is essential that an appointment be made beforehand. This can be done by letter or telephone, and will avoid disappointment.

Orders should always be sent in list form and not as part of a letter.

When writing on a technical matter always quote your frame and engine numbers. A space is provided below for easy reference.

MODEL No.	
FRAME NUMBER	ENGINE NUMBER

NOTE : We reserve the right to alter any of the prices quoted in this list, without notice.

# Spring Frame

225 cc. COLONEL — 1955 MODEL K12

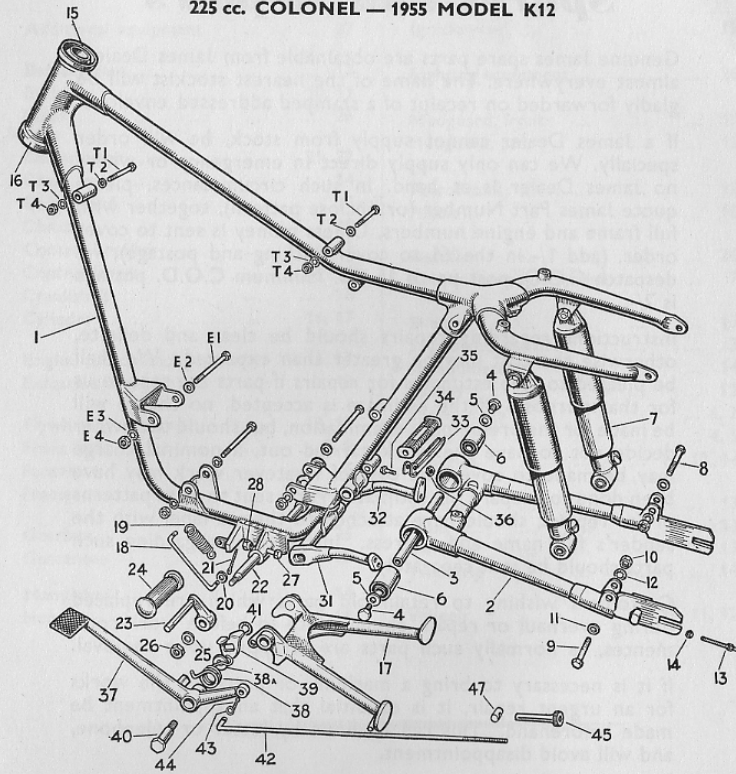

NOTE: On the K12 225 cc. Colonel the frame has 4 engine fixing lugs and bolts.

**Insist upon Genuine James Spares**

## SPRING FRAME 225 cc. COLONEL — 1955 MODEL K12

Ill. No.	Description of Part	Qty.	Part No.	Price each £ s. d.
1	Frame assembly, front ... ..	1	002080	11 0 0
2	Rear suspension pivoting fork ... ..	1	001778	3 10 0
3	" " pivot tube ... ..	1	001878	1 2 6
4	" " hex bolt $\frac{1}{2}$ " x 26 t.p.i. ... ..	2	001879	6
5	" " washer $\frac{1}{2}$ " x 16 s.w.g. x $1\frac{3}{16}$ " o.d. ... ..	2	900197	3
6	" " torsion bush ... ..	2	001973	4 0
7	" " telescopic unit complete ... ..	2	002145	3 5 0
—	" " hex bolt $\frac{3}{8}$ " x 26 t.p.i. x $1\frac{3}{4}$ " ... ..	3	900198	8
9	" " hex bolt $\frac{3}{8}$ " x 26 t.p.i. x $1\frac{7}{8}$ " ... ..	1	900313	8
10	" " hex nut $\frac{3}{8}$ " x 26 t.p.i. ... ..	4	900021	3
11	" " washer $\frac{3}{8}$ " dia. ... ..	4	900011	1
12	" " shakeproof washer $\frac{3}{8}$ " dia. ... ..	4	900002	1
13	Chain adjuster bolt ... ..	2	900387	3
14	" " locknut ... ..	2	900023	2
15	Frame ball race top or bottom ... ..	2	002378	1 9
16	" " enclosure cup ... ..	1	001011	1 9
17	Centre stand ... ..	1	002129	16 6
18	" " operating rod ... ..	1	002139	1 0
19	Centre stand spring ... ..	1	002140	1 0
20	" " plain washer $\frac{1}{16}$ " dia. ... ..	1	900162	1
21	" " split pin $\frac{1}{16}$ " x $\frac{3}{4}$ " ... ..	1	900121	1
22	Footrest bar ... ..	1	002123	7 6
23	" " hanger ... ..	2	002147	4 0
24	" " rubber ... ..	2	002026	1 6
25	" " washer $\frac{7}{16}$ " x 14 s.w.g. ... ..	—	900033	1
26	" " hex nut $\frac{7}{16}$ " x 26 t.p.i. x $\frac{5}{16}$ " ... ..	—	900035	3
27	" " locking bolt $\frac{5}{16}$ " x 26 t.p.i. ... ..	2	900311	4
28	" " locking hex nut ... ..	2	900312	2
31	Pillion footrest hanger ... ..	1	003113	5 6
33	" " pressing ... ..	2	002203	1 9
34	" " rubber ... ..	2	002204	1 6
35	" " hex bolt $\frac{1}{2}$ " x 26 t.p.i. x $\frac{7}{8}$ " long ... ..	2	900024	2
36	" " nut $\frac{1}{4}$ " x 26 t.p.i. x $\frac{7}{8}$ " long ... ..	2	900027	2
37	Rear brake pedal ... ..	1	002053	12 6
38	" " return spring ... ..	1	002119	1 0
39	" " pedal adjuster ... ..	1	002142	2 0
40	" " pivot bolt ... ..	1	002141	1 6
41	" " shakeproof washer L.H. serrations ... ..	1	900333	2
42	" " rod ... ..	1	002367	1 9
43	" " plain washer $\frac{1}{4}$ " dia. ... ..	1	900162	1
44	" " split pin $\frac{1}{16}$ " x $\frac{3}{4}$ " ... ..	1	900121	1
45	" " rod adjuster K7 ... ..	1	000342	2 0
47	" " roller ... ..	1	002382	1 0
E1	Engine bolts $\frac{3}{8}$ " x 20 t.p.i. x $2\frac{3}{4}$ " long ... ..	4	900331	10
E2	" " plain washer ... ..	8	900011	1
E3	" " shakeproof washer ... ..	4	900002	1
E4	" " hex nut ... ..	4	900017	3
TD1	Rear tank and dualseat bolt $2\frac{1}{2}$ " x $\frac{5}{16}$ " x 26 t.p.i. ... ..	1	900119	4
T1	Front tank bolt $2\frac{1}{8}$ " x $\frac{5}{16}$ " x 26 t.p.i. ... ..	1	900074	8
T2	" " plain washer ... ..	2	900009	1
T3	" " shakeproof washer ... ..	2	900003	1
T4	" " hex nut $\frac{5}{16}$ " x 26 t.p.i. ... ..	2	900000	2

# Spring Units

225 cc. COLONEL — 1955 MODEL K12

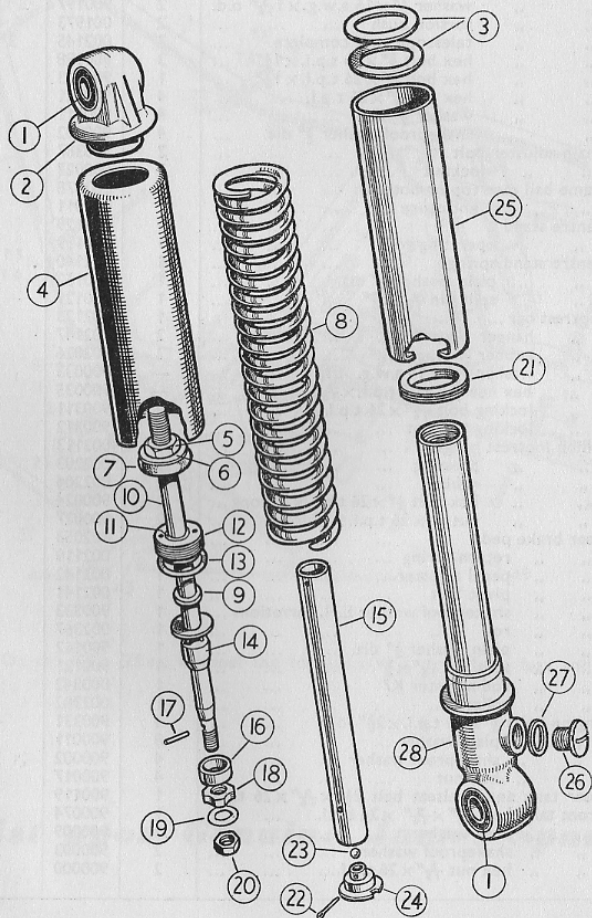

## SPRING UNITS 225 cc. COLONEL — 1955 MODEL K12

Ill. No.	Description of Parts	Qty.	Part No.	Price each £ s. d.
1	Rubber torsion bush ... ..	4	002810	3 6
2	Top spring anchorage ... ..	2	002794	4 0
3	Washer for spring cover ... ..	4	002808	3
4	Outer cover ... ..	2	002806	4 3
5	Lock nut ... ..	2	900345	3
6	Buffer washer ... ..	2	900014	2
7	Rubber buffer ... ..	2	002811	9
8	Spring (medium) ... ..	2	002650	11 6
—	Spring (heavy) ... ..	2	002780	11 6
9	Inner gland seal ... ..	2	002801	1 9
10	Damper rod ... ..	2	002798	3 0
11	Damper gland bush ... ..	2	002800	1 6
12	Damper gland ... ..	2	002799	3 9
13	Outer gland seal ... ..	2	002802	1 9
14	Damper rod guides ... ..	2	002803	9
15	Damper tube ... ..	2	002797	1 6
16	Damper valve ... ..	2	002805	1 3
17	Damper valve pin ... ..	2	900344	2
18	Damper valve seats ... ..	2	002804	4
19	Plain washer ... ..	2	900348	2
20	Hex nut ... ..	2	900347	4
21	Grummet for inner spring cover ... ..	2	002809	9
22	Split pin for valve body ... ..	2	900121	1
23	Non return valve ball $\frac{1}{8}$ " dia. ... ..	2	900201	1
24	Non return valve body ... ..	2	002795	1 3
25	Inner cover ... ..	2	002807	7 6
26	Filler and drain plug ... ..	2	900109	9
27	Plug washer ... ..	2	000165	2
28	Bottom spring anchorage ... ..	2	002793	14 0

### IMPORTANT

ORDERS FOR SPARE PARTS SHOULD ALWAYS BE SENT IN LIST FORM ON ONE SIDE OF A SHEET OF PAPER AND NOT AS PART OF A LETTER.

THE COMPLETE FRAME AND ENGINE NUMBERS AS WELL AS PART NUMBERS AND DESCRIPTIONS SHOULD BE QUOTED ON EACH ORDER.

OLD PARTS SENT AS PATTERNS WILL BE SCRAPPED UNLESS CUSTOMER SPECIFIES OTHERWISE.

# Front Fork

225 cc. COLONEL — 1955 MODEL K12

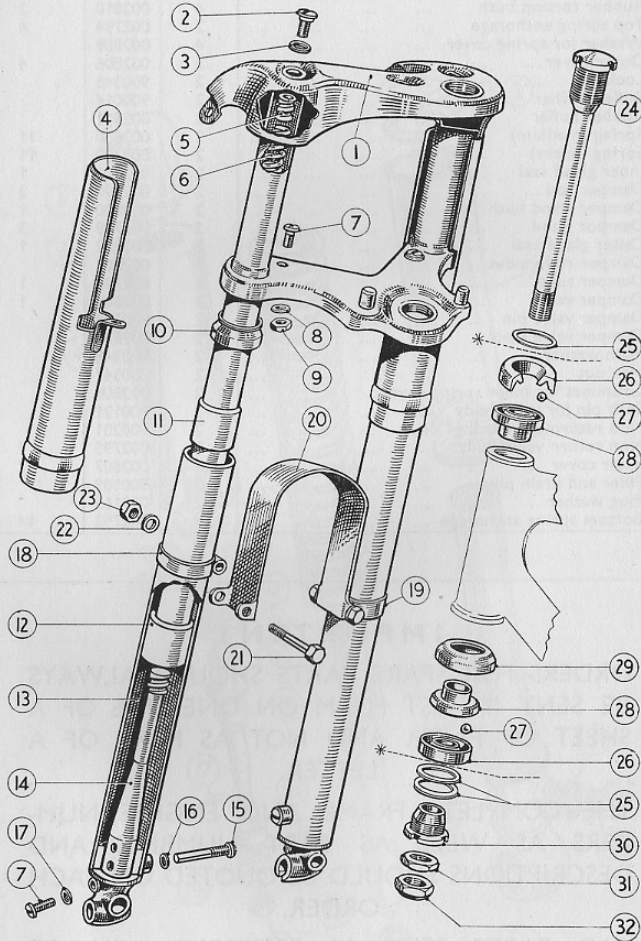

(\* denotes parts fitting above and below fork crown and top plate)

## FRONT FORK

225 cc. COLONEL — 1955 MODEL K12

Ill. No.	Description of Part	Qty.	Part No.	Price each £ s. d.
—	Front Fork complete ... ..	1	002900	15 0 0
1	Fork "H" assembly inc. crown and top plate ...	1	002902	4 4 0
2	Oil filler plug $\frac{5}{16}$ " $\times$ 26 t.p.i. ... ..	2	900364	9
3	Fibre washer ... ..	2	900144	2
4	Top cover sleeve ... ..	2	002938	10 0
5	Spring adaptor — top end ... ..	2	002949	2 0
6	Coil spring ... ..	2	002948	12 6
7	Screw for drain plug and top cover fixing $\frac{1}{4}$ " $\times$ 26	4	900315	3
8	Shakeproof washer ... ..	2	900004	1
9	Hex. nut $\frac{1}{4}$ " $\times$ 26 t.p.i. ... ..	2	900027	2
10	Oil seal ... ..	2	003018	2 6
11	Upper fork bearing bush ... ..	2	002907	4 9
12	Lower fork bearing bush ... ..	2	002906	4 9
13	Slider tube and fork end ... ..	2	002910	1 15 0
14	Damper post with lower spring adaptor ... ..	2	002932	7 6
15	Damper post retaining bolt ... ..	2	002917	5
16	Fibre washer $\frac{5}{16}$ " dia. (post screw) ... ..	2	900358	1
17	Seloc washer (drain plug) ... ..	2	900102	2
—	Screw ... ..	—	900315	2
18	Mudguard bridge clip L.H. with cable stop ...	1	003199	3 6
19	Mudguard bridge clip R.H. ... ..	1	003020	2 6
20	Bridge piece ... ..	1	003023	2 6
21	Clip bolt $\frac{5}{16}$ " $\times$ 26 t.p.i. ... ..	2	900094	8
22	Plain washer $\frac{5}{16}$ " dia. ... ..	2	900009	1
23	Hex. nut $\frac{5}{16}$ " $\times$ 26 t.p.i. ... ..	2	900000	2
24	Steering stem ... ..	1	002918	10 0
25	Shim $1\frac{1}{8}$ " $\times$ .020" ... ..	4	002936	2
26	Fork ball race ... ..	2	002921	—
27	Ball bearings $\frac{1}{4}$ " dia. ... ..	34	000371	set 2 0
28	Frame ball race ... ..	2	002378	1 9
29	Lower fork race cover ... ..	1	002942	1 9
30	Fork crown bearing adaptor ... ..	1	002922	3 0
31	Steering stem adjusting nut $\frac{3}{8}$ " $\times$ 26 t.p.i. ...	1	900353	9
32	Steering stem locknut ... ..	1	900352	9

### EXCHANGE SERVICE

A ROTARY EXCHANGE SERVICE IS AVAILABLE TO OWNERS RESIDENT IN THE U.K. COMPONENTS WHICH MAY BE EXCHANGED FOR RECONDITIONED UNITS INCLUDE: FRONT FORK, REAR SUSPENSION UNITS, CYLINDER, CRANKSHAFT ASSEMBLY, CLUTCH PLATES, MAGNETO, CARBURETTER, BRAKE SHOES AND LININGS, FRAME, TANK AND WHEELS.

PRICES OBTAINABLE UPON APPLICATION TO SERVICE DEPARTMENT

# Wheels and Brakes

225 cc. COLONEL — 1955 MODEL K12

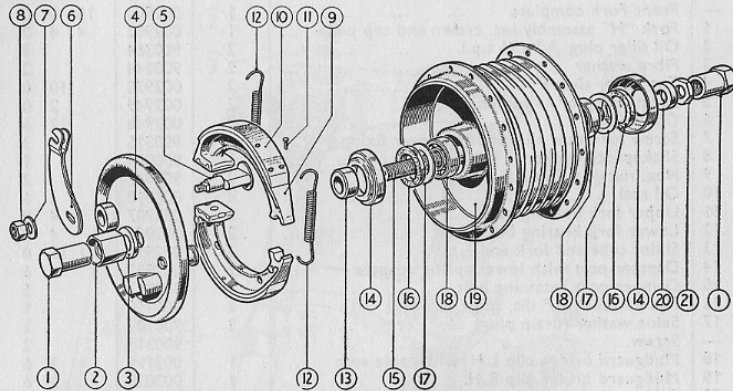

FRONT HUB — 6" BRAKE

Ill. No.	Description of Part	Qty.	Part No.	Price each £ s. d.
—	Front hub and brake complete 6" dia. ...	1	002955	7 10 0
1	Spindle nut $\frac{9}{16}$ " x 26 t.p.i. ...	2	900356	2 6
2	Recessed locknut hex $\frac{9}{16}$ " x 26 t.p.i. ...	1	900306	1 3
3	Spacer $\frac{3}{8}$ " thick ...	2	001337	9
4	Brake back plate 6" ...	1	003090	15 0
5	Brake cam ...	1	002051	4 0
6	Brake cam lever ...	1	002924	2 6
7	Cam lever washer ...	1	003086	2
—	Brake cam spacer washer ...	1	900137	3
8	Hex nut $\frac{5}{8}$ " x 26 t.p.i. ...	1	900000	2
9	Brake shoe and liner ...	2	002281	pr. 15 0
10	Brake lining ...	2	001822	pr. 6 0
11	Brake lining rivets $\frac{11}{16}$ " long ...	14	900145	set 6
12	Return spring ...	2	001819	6
13	Spacer $\frac{1}{2}$ " thick ...	1	001335	9
14	Bearing seal enclosure cup R.H. ...	1	001850	4
—	Bearing seal enclosure cup ...	1	000942	4
15	Hub spindle $\frac{9}{16}$ " dia. ...	1	002928	9 0
16	Felt seal ...	2	000941	3
17	Enclosure washer ...	2	000940	3
18	Journal bearing 15 x 35 x 11 mm. ...	2	001333	11 8
19	Hub shell, 6" brake drum ...	1	002696	3 15 0
20	Spacer $\frac{3}{8}$ " thick ...	1	001337	9
21	Locknut $\frac{9}{16}$ " x 26 x $\frac{3}{16}$ " ...	1	900289	3

# WHEELS AND BRAKES

225 cc. COLONEL — 1955 MODEL K12.

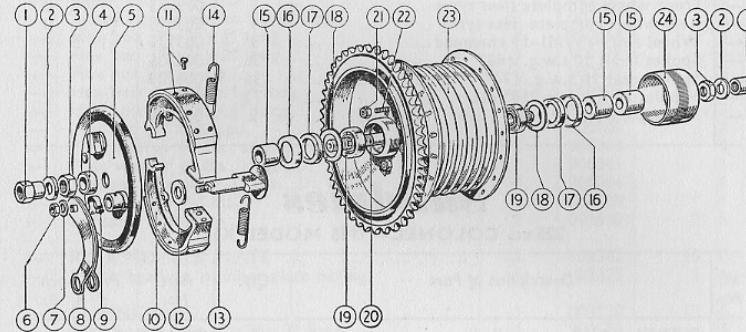

REAR HUB — 6" BRAKE

Ill. No.	Description of Part	Qty.	Part No.	Price each £ s. d.
—	Rear hub and brake complete ...	1	002952	8 10 0
1	Spindle nut $\frac{9}{16}$ " x 26 t.p.i. ...	2	900047	2 6
2	Plain washer $\frac{9}{16}$ " x 10 s.w.g. ...	2	900015	1
3	Locknut $\frac{9}{16}$ " x 26 x $\frac{3}{8}$ " ...	2	900051	3
4	Spacer $\frac{3}{8}$ " long ...	1	001337	9
5	Backplate ...	1	001813	18 6
6	Hex nut $\frac{5}{8}$ " x 26 t.p.i. ...	1	900000	2
7	Plain washer ...	1	900166	1
8	Brake cam lever ...	1	001816	3 0
9	Oiler spring clip ...	1	001418	3
10	Brake shoe and liner complete ...	2	002281	pr. 15 0
—	Brake lining ...	2	001822	pr. 6 0
11	Rivets $\frac{11}{16}$ " long ...	14	900145	set 6
12	Brake cam washer ...	1	900137	1
13	Brake cam ...	1	001808	4 0
14	Return spring ...	2	001819	6
15	Spacer $\frac{3}{8}$ " long ...	3	001336	9
16	Enclosure cup, bearing seal ...	2	003006	6
17	Felt seal ...	2	003007	6
18	Enclosure washer, bearing seal ...	2	003005	3
19	Ball bearing 42 x 15 x 13 mm. ...	2	003008	14 3
20	Spindle ...	1	002961	10 0
21	Hex nut, self locking $\frac{1}{4}$ " x 26 t.p.i. ...	6	900284	4
22	Brake drum and sprocket ...	1	003142	3 0 0
23	Hub shell ...	1	002957	2 0 0
24	Outer cover ...	1	002980	2 6

**WHEELS AND SPOKES**  
225 cc. COLONEL — 1955 MODEL K12

Ill. No.	Description of Part	Qty.	Part No.	Price each £ s. d.
—	Front wheel complete (less tyre) ... ..	1	003073	9 10 0
—	Rear wheel complete (less tyre) ... ..	1	003115	10 10 0
—	Wheel rim — WM1-19 chromed ... ..	2	003135	1 5 0
—	Spokes front 10 s.w.g. x 6 <sup>7</sup> / <sub>8</sub> " ... ..	36	002506	2
—	Spokes rear 10 s.w.g. x 7 <sup>7</sup> / <sub>8</sub> " ... ..	36	003139	2
—	Nipples 10 s.w.g. x .250" dia. ... ..	72	000254	2
—	Rim tape, front or rear ... ..	2	000190	9

**Sundries**

225 cc. COLONEL — 1955 MODEL K12

Ill. No.	Description of Part	Qty.	Part No.	Price each £ s. d.
—	PETROL TANK, enamelled ... ..	1	003162	6 6 0
—	" " " chromed panels ... ..	1	003191	7 16 0
—	Front tank bracket ... ..	1	003179	7 6
—	Hex bolt, tank bracket <sup>5</sup> / <sub>16</sub> " x 26 x 2 <sup>1</sup> / <sub>8</sub> " long ... ..	1	900074	4
—	Hex bolt, tank, rear, <sup>5</sup> / <sub>16</sub> " x 26 x 2 <sup>1</sup> / <sub>2</sub> " long ... ..	1	900119	4
—	Hex bolt, tank, front, <sup>5</sup> / <sub>16</sub> " x 26 x 1 <sup>1</sup> / <sub>4</sub> " long ... ..	2	900171	3
—	Plain washer <sup>5</sup> / <sub>16</sub> " dia. ... ..	6	900009	1
—	Hex nut <sup>5</sup> / <sub>16</sub> " x 26 t.p.i. ... ..	2	900000	2
—	Knee grip rubber, L.H. ... ..	1	002365	4 0
—	Knee grip rubber, R.H. ... ..	1	002366	4 0
—	Petrol tap ... ..	1	003166	5 6
—	Drain plug ... ..	1	900376	3
—	Fibre washer, tap or plug ... ..	1	900373	1
—	Petrol pipe, plastic ... ..	1	002181	1 6
—	Ferrule for petrol pipe ... ..	2	002063	4
—	Banjo union to carburetter ... ..	1	002000	1 9
—	Filler cap and oil measure ... ..	1	003167	6 0
—	Fibre washer, filler cap ... ..	1	900161	3
—	Tank badge ... ..	2	002393	1 6
—	Rubber moulding, badge ... ..	2	002816	1 0
—	Screw, badge fixing ... ..	4	900325	1
—	FRONT MUDGUARD, with number plate brackets ... ..	1	003017	1 10 0
—	Tubular stay, front mudguard ... ..	1	003013	6 0
—	Bridge piece, front mudguard ... ..	1	003023	4 0
—	Attachment clip, front mudguard L.H. ... ..	1	003199	3 6
—	Attachment clip, front mudguard R.H. ... ..	1	003020	2 6
—	Hex bolt, domed, <sup>5</sup> / <sub>16</sub> " x 26 x 1 <sup>3</sup> / <sub>4</sub> " long ... ..	2	900094	8
—	Hex bolt, domed, <sup>5</sup> / <sub>16</sub> " x 26 x <sup>3</sup> / <sub>8</sub> " long ... ..	2	900354	3
—	Plain washer <sup>5</sup> / <sub>16</sub> " dia. ... ..	4	900009	1
—	Hex nut <sup>5</sup> / <sub>16</sub> " x 26 t.p.i. ... ..	2	900000	2
—	Mush head screw <sup>1</sup> / <sub>4</sub> " x 26 t.p.i. ... ..	4	900315	3
—	Shakeproof washer <sup>1</sup> / <sub>4</sub> " dia. ... ..	4	900004	1
—	Hex nut <sup>1</sup> / <sub>4</sub> " x 26 t.p.i. ... ..	4	900027	2
—	FRONT NUMBER PLATE ... ..	1	002375	2 6
—	Round head screw <sup>3</sup> / <sub>16</sub> " x 26 t.p.i. ... ..	2	900010	1
—	Shakeproof washer <sup>3</sup> / <sub>16</sub> " dia. ... ..	2	900060	1
—	Hex nut <sup>3</sup> / <sub>16</sub> " x 26 t.p.i. ... ..	2	900016	1

**SUNDRIES — continued.**

Ill. No.	Description of Part	Qty.	Part No.	Price each £ s. d.
—	REAR MUDGUARD ... ..	1	002337	1 15 0
—	Aluminium spacer to frame stays ... ..	2	002341	2 6
—	Hex bolt <sup>1</sup> / <sub>4</sub> " x 26 x <sup>5</sup> / <sub>8</sub> " long ... ..	2	900054	3
—	Hex bolt <sup>1</sup> / <sub>4</sub> " x 26 x 2" long ... ..	1	900178	4
—	Hex nut <sup>1</sup> / <sub>4</sub> " x 26 t.p.i. ... ..	6	900027	2
—	Hex bolt <sup>5</sup> / <sub>16</sub> " x 26 x 1 <sup>1</sup> / <sub>2</sub> " long ... ..	2	900108	4
—	Hex bolt <sup>5</sup> / <sub>16</sub> " x 26 x <sup>1</sup> / <sub>2</sub> " long ... ..	2	900133	3
—	Hex nut <sup>5</sup> / <sub>16</sub> " x 26 t.p.i. ... ..	2	900000	2
—	Plain washer <sup>1</sup> / <sub>4</sub> " dia., small ... ..	8	900008	1
—	Plain washer <sup>1</sup> / <sub>4</sub> " dia., large ... ..	5	900045	1
—	Shakeproof washer <sup>1</sup> / <sub>4</sub> " dia. ... ..	4	900004	1
—	Plain washer <sup>5</sup> / <sub>16</sub> " dia. ... ..	6	900009	1
—	Reflector complete ... ..	1	002660	2 6
—	REAR NUMBER PLATE ... ..	1	002342	10 0
—	Plastic beading, number plate fairing ... ..	1	003225	1 6
—	CHAINGUARD ... ..	1	002120	12 6
—	Attachment bolt <sup>1</sup> / <sub>4</sub> " x 26 x 2" long ... ..	1	900178	4
—	Plain washer <sup>1</sup> / <sub>4</sub> " dia. ... ..	1	900008	1
—	Shakeproof washer <sup>1</sup> / <sub>4</sub> " dia. ... ..	1	900004	1
—	Hex nut <sup>1</sup> / <sub>4</sub> " x 26 t.p.i. ... ..	1	900027	2
—	TWINSEAT ... ..	1	003039	3 16 0
—	Hex bolt <sup>1</sup> / <sub>4</sub> " x 26 x <sup>5</sup> / <sub>8</sub> " long ... ..	2	900054	3
—	Plain washer <sup>1</sup> / <sub>4</sub> " dia. ... ..	4	900008	1
—	Hex nut <sup>1</sup> / <sub>4</sub> " x 26 t.p.i. ... ..	2	900027	2
—	Rubber buffer ... ..	2	002128	5
—	EXHAUST PIPE ... ..	1	002294	1 10 0
—	Silencer complete ... ..	1	002297	1 15 0
—	Silencer body ... ..	1	002547	17 0
—	Inner tube and tail pipe ... ..	1	002557	16 0
—	Self tapping screws ... ..	4	900155	1
—	Hex bolt <sup>5</sup> / <sub>16</sub> " x 26 x <sup>1</sup> / <sub>2</sub> " long ... ..	1	900133	3
—	Plain washer <sup>5</sup> / <sub>16</sub> " dia. ... ..	1	900009	1
—	TOOLBOX ... ..	1	002086	17 6
—	Thumb screw ... ..	1	000641	1 6
—	Tapped washer ... ..	1	900350	1
—	Plain washer <sup>1</sup> / <sub>4</sub> " dia. ... ..	—	900008	1
—	Hex nut ... ..	—	900027	2
—	BATTERY CASE ... ..	1	002085	17 6
—	Platform, battery ... ..	1	002371	1 6
—	Rubber pad ... ..	2	002368	6
—	Thumb screw ... ..	1	000641	1 6
—	Tapped washer ... ..	1	900350	2
—	TOOL KIT, complete in wallet ... ..	1	—	1 1 0
—	Tool wallet only ... ..	1	000553	3 0
—	Plug spanner ... ..	1	002539	3 0
—	Magneto point spanner and gauge ... ..	1	000438	7
—	Screwdriver ... ..	1	000551	1 0
—	Exhaust pipe spanner ... ..	1	002503	3 0
—	D.E. spanner -525 x -601 ... ..	1	000546	3 0
—	D.E. spanner -338 x -448 ... ..	1	000545	3 0



SUNDRIES — continued.

Ill. No.	Description of Part	Qty.	Part No.	Price each £ s. d.
—	D.E. spanner .720 x .820 ... ..	1	001996	1 6
—	Tyre lever ... ..	2	000544	1 6
—	Pliers ... ..	1	002537	4 0
—	Pump and connector ... ..	1	000595	6 6
—	REAR CHAIN 125 links ... ..	1	002394 *	
—	HANDLEBAR with ball joints and pivot brackets	1	002937	1 17 6
—	Spherical recessed washer ... ..	2	002923	1 6
—	Hex bolt 1/2" x 26 t.p.i. ... ..	2	900369	8
—	FRONT BRAKE LEVER, handle only ... ..	1	001312	7 6
—	Front brake cable complete ... ..	1	003059	5 6
—	CLUTCH LEVER, handle only ... ..	1	001311	7 6
—	Clutch cable complete ... ..	1	001585	5 6
—	Handlebar lever pivot pin 1/4" x 26 t.p.i. ... ..	2	900135	2
—	Handlebar lever hex nut 1/4" x 26 t.p.i. ... ..	2	900023	1
—	TWISTGRIP complete ... ..	1	002644	12 6
—	Grip sleeve ... ..	1	000282	3 0
—	Grip rubber ... ..	1	002642	2 3
—	Clip, abutment half ... ..	1	000283	3 6
—	Clip, cover half ... ..	1	000284	3 6
—	Clamp pin 1 BA ... ..	2	900087	1
—	Adjusting screw ... ..	1	900089	1
—	Hex locknut ... ..	1	900086	1
—	Friction spring ... ..	1	000286	6
—	Cable slotted socket ... ..	1	000285	3
—	Rubber grip, L.H. ... ..	1	002643	2 3
—	SPEEDOMETER HEAD — miles per hour ... ..	1	003146	2 15 0
—	" " — kilos per hour ... ..	1	003643	2 15 0
—	Speedo drive cable complete 3' long ... ..	1	002349	1 2 6
—	SPARK PLUG ... ..	1	000436	5 6
—	Plug cover and suppressor ... ..	1	001617	

\* Manufacturers current price.

# Engine and Contact Breaker

225 cc. COLONEL — 1955 MODEL K12

Ill. No.	Description of Part	Qty.	Part No.	Price each £ s. d.
1	Strangler fixing screws ... ..	2	700896	2
2	" plate and cover ... ..	1	702244	4 0
3	Carburetter cover ... ..	1	702245	17 6
4	Waterproof cover for carburetter cable... ..	1	702246	6
5	Tickler ... ..	1	702247	6
—	" spring ... ..	1	702012	2
—	" split pin ... ..	1	702027	1
6	Circlip for gauze ... ..	1	702248	6
7	Plate for carburetter cover ... ..	1	702249	6
8	Air filter gauze ... ..	1	702250	6 0
9	Cylinder head bolt ... ..	4	700378	1 0
10	" " bolt washer ... ..	4	900011	1
11	" " ... ..	1	704225	2 0 0
12	" " gasket ... ..	1	704226	6
13	Cylinder ... ..	1	704227	5 0 0
14	Exhaust nut washer ... ..	1	704228	4
15	" pipe nut ... ..	1	704229	4 0
16	Carburetter cover dowel ... ..	1	704230	2
17	Inlet pipe studs ... ..	2	700376	3
18	" " joint washer ... ..	1	704232	2
19	Inlet pipe ... ..	1	704233	7 6
20	Washer for inlet pipe studs ... ..	2	700662	1
21	Nut for inlet pipe studs ... ..	2	700197	2
22	Cylinder base joint washer ... ..	1	704236	2
23	Chaincase filler cap ... ..	1	704048	1 3
24	" filler cap washer ... ..	1	704049	2
25	" front ... ..	1	704239	1 0 0
—	" nameplate ... ..	1	704240	2 0
—	" nameplate fixing screw ... ..	3	704241	2
26	" cover screw ... ..	1	700043	6
—	" cover screw ... ..	3	700046	3
27	" level screw ... ..	1	704068	3
28	Level screw washer ... ..	1	700283	1
29	Chaincase joint washer ... ..	1	704246	1 3
30	" back ... ..	1	704247	1 10 0
—	" fixing screw, back half ... ..	2	704248	2
31	" gland plate rivets ... ..	4	700176	per set 6
32	" gland plate washer ... ..	1	704250	3
33	" gland plate ... ..	1	704251	6
34	" fixing stud nut ... ..	2	900038	2
35	Spring washer for stud ... ..	2	900004	1
36	Plain washer for stud ... ..	2	900008	1
37	Chaincase fixing stud ... ..	2	700844	3
38	Gearbox body ... ..	1	704256	3 0 0
39	Carburetter cover screw ... ..	1	704257	9
40	Dipstick complete ... ..	1	704258	2 0
41	Gearbox filler plug washer ... ..	1	700281	1
42	" joint washer ... ..	1	704260	3
43	" dowel ... ..	4	700030	3
44	" drain plug washer ... ..	1	700282	1
45	" drain plug ... ..	1	700254	1 3
46	" end plate joint washer ... ..	1	704264	2
47	" end cover screw, medium ... ..	2	700019	4
48	" end cover screw, short ... ..	2	700046	3
49	" end cover screw, long ... ..	2	704267	4

**ENGINE AND CONTACT BREAKER**  
225 cc. COLONEL — 1955 MODEL K12

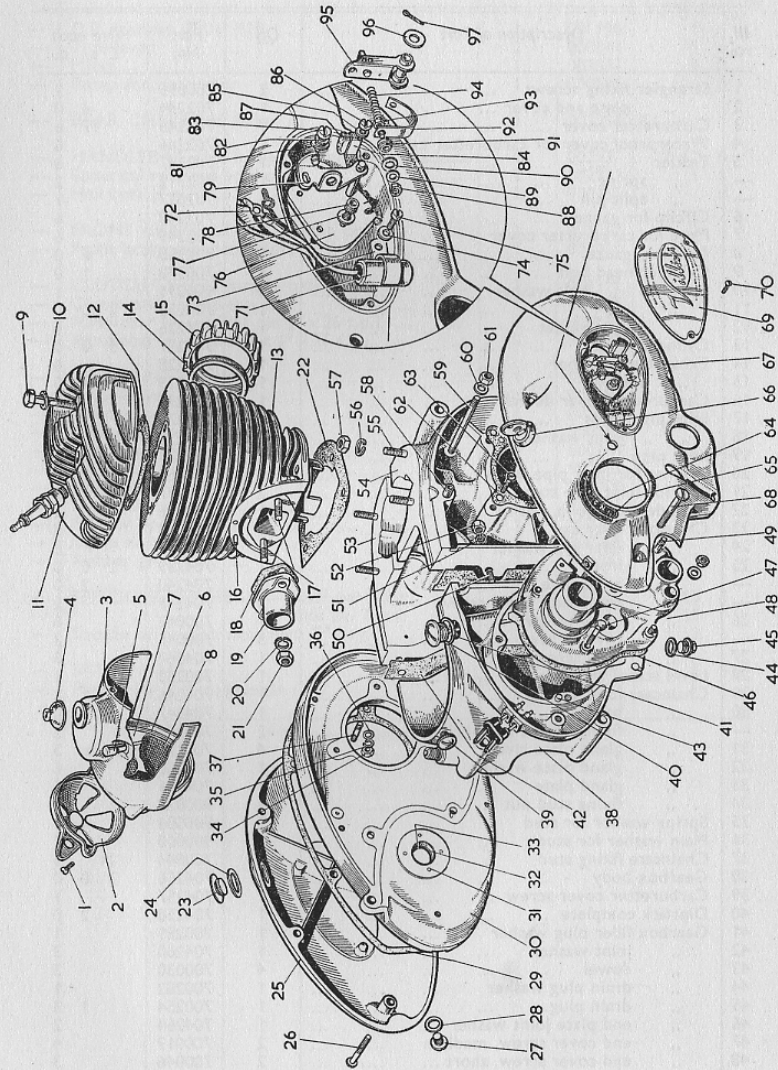

**ENGINE AND CONTACT BREAKER — continued.**

Ill. No.	Description of Part	Qty.	Part No.	Price each £ s. d.
50	Gearbox fixing stud ... ..	4	700948	3
51	„ fixing stud washer ... ..	4	700662	1
52	„ fixing stud nut ... ..	4	700091	2
53	Crankcase, left hand ... ..	1	704271	2 10 0
54	„ right hand ... ..	1	704272	2 10 0
—	„ drain screw ... ..	1	700257	3
—	„ drain screw washer ... ..	1	700283	1
55	Cylinder base stud ... ..	4	700948	3
56	„ base stud washer ... ..	4	700662	1
57	„ base stud nut ... ..	4	700197	2
58	R.H. crankcase dowel ... ..	2	704278	3
59	Crankcase fixing stud ... ..	4	704279	6
60	„ fixing stud washer ... ..	8	900008	1
61	„ fixing stud nut ... ..	8	900038	2
—	„ fitting stud ... ..	2	704282	6
—	„ fitting stud washer ... ..	4	900008	1
—	„ fitting stud nut ... ..	4	900038	2
62	Armature plate joint washer ... ..	1	704285	2
63	„ fixing screw ... ..	4	700887	3
64	Plate for gear indicator ... ..	1	704287	3
65	Fixing screw for plate ... ..	2	704288	2
66	Ignition switch complete ... ..	1	703170	12 0
67	Magneto cover ... ..	1	703171	1 5 0
68	„ screw ... ..	1	700043	6
69	Contact breaker cover ... ..	1	703172	2 0
70	„ fixing screw ... ..	3	703173	2
71	Condenser ... ..	1	703174	5 0
72	„ lead shoe ... ..	1	703175	1
73	„ clip ... ..	1	703176	2
74	„ clip screw washer ... ..	1	703047	1
75	„ clip screw ... ..	1	700204	2
76	Contact breaker base plate ... ..	1	703177	1 6
—	Cam for contact breaker ... ..	1	703178	3 0
—	Key for cam ... ..	1	703179	4
—	Circlip for ignition cam ... ..	1	703180	3
77	Washer for C.B. base plate screw ... ..	1	703181	1
78	Screw for C.B. base plate ... ..	1	703182	6
79	Point bracket ... ..	1	703183	2 3
81	„ lock screw washer ... ..	1	703024	1
82	Adjuster plate clamp screw washer ... ..	1	700265	1
83	Point bracket screw ... ..	1	703025	2
84	Oil pad clip ... ..	1	703184	3
85	Washer for oil pad clip screw ... ..	1	703047	1
86	Screw for oil pad clip ... ..	1	700204	2
87	Oil pad ... ..	1	703185	2
88	L.T. terminal nut ... ..	1	703139	2
89	„ washer ... ..	1	703023	1
90	„ screw washer ... ..	1	703024	1
91	„ bush ... ..	1	703138	4
92	Rocker arm earthing strip ... ..	1	703186	2
93	Point bracket pin ... ..	1	703140	2
94	Rocker arm spring ... ..	1	703033	2
95	Rocker arm ... ..	1	703136	5 0
96	Washer for rocker arm pivot pin ... ..	1	700265	1
97	Split pin for rocker arm pivot pin ... ..	1	702027	1

## Crankshaft and Piston

225 cc. COLONEL — 1955 MODEL K12

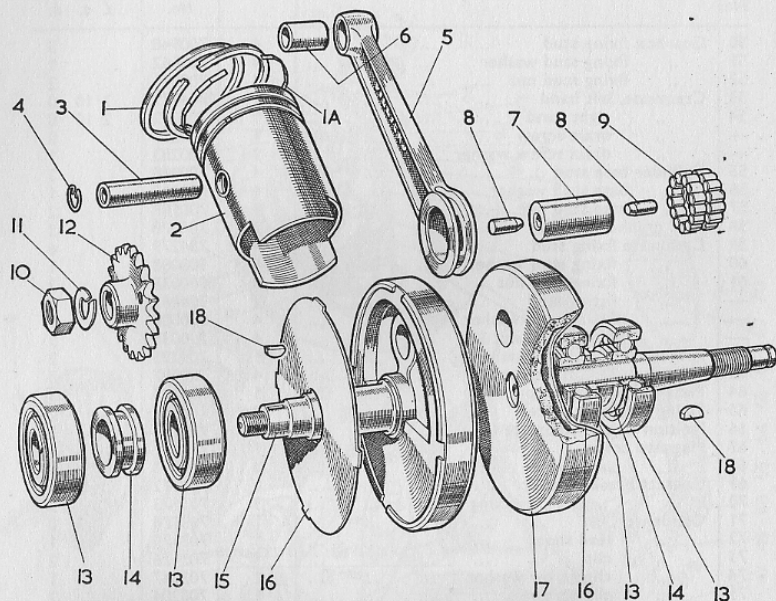

Ill. No.	Description of Part	Qty.	Part No.	Price each £ s. d.
—	Crankshaft assembly complete ... ..	1	704455	6 0 0
1	Piston rings ... ..	2	704445	1 9
1A	Expander ring ... ..	1	704446	1 0
2	Piston with bushes ... ..	1	704447	1 10 0
3	Gudgeon pin ... ..	1	704448	3 6
4	„ circlips ... ..	2	700289	3
5	Connecting rod with bush .001" O/S ... ..	1	704450	1 0 0
6	„ bush ... ..	1	700367	2 0
7	Crankpin .001" O/S... ..	1	704452	5 0
8	„ plugs ... ..	2	700365	3
9	Rollers for crankpin 1/4" x 1/4" ... ..	26	700188	set 8 0
10	Engine sprocket nut ... ..	1	700219	6
11	„ washer ... ..	1	700277	1
12	Engine sprocket, 20 teeth ... ..	1	704457	9 0
13	Ball bearing for crankshaft... ..	4	704458	*
14	Driveshaft ball bearing distance piece ... ..	2	704459	1 3
15	Driving shaft, left hand ... ..	1	704460	2 2 0
16	Cover plate for driveshaft balance weight ... ..	2	704461	1 0
17	Driveshaft, right hand ... ..	1	704462	2 2 0
18	Engine sprocket and flywheel key ... ..	2	700370	3

\* Manufacturers current price

## Flywheel Generator

225 cc. COLONEL — 1955 MODEL K12

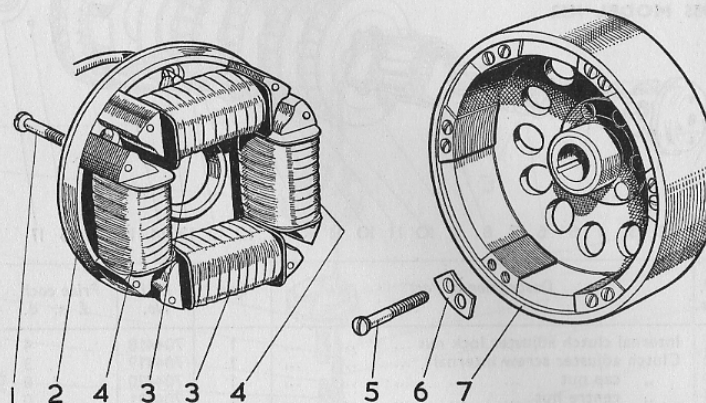

Ill. No.	Description of Part	Qty.	Part No.	Price each £ s. d.
1	Coil cheek screws ... ..	8	703063	3
2	Armature plate assembly complete ... ..	1	703187	3 10 0
3	Lighting coils ... ..	1 pr.	703188	1 10 0
4	Ignition coils — armature plate ... ..	1 pr.	703189	1 5 0
5	Pole screws ... ..	12	703073	3
6	Pole shoe top plates ... ..	6	703072	3
7	Flywheel assembly complete ... ..	1	703190	6 10 0

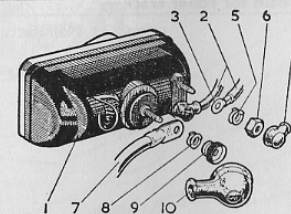

## Ignition Coil

Ill. No.	Description of Part	Qty.	Part No.	Price each £ s. d.
1	Ignition coil assembly complete, comprising coil, base plate and cover ... ..	1	002361	3 0 0
2	L.T. lead ... ..	2	703191	1 6
3	„ lead shoe ... ..	2	703192	2
4	„ terminal cover ... ..	2	703193	3
5	„ terminal washer ... ..	2	702050	1
6	„ terminal nut ... ..	2	703194	4
7	H.T. lead 7 mm. ... ..	1	703195	2 6
8	„ terminal washer ... ..	1	702050	1
9	„ terminal nut ... ..	1	703196	3
10	„ terminal cover ... ..	1	703197	1 3

# Clutch

225 cc. COLONEL  
1955 MODEL K12

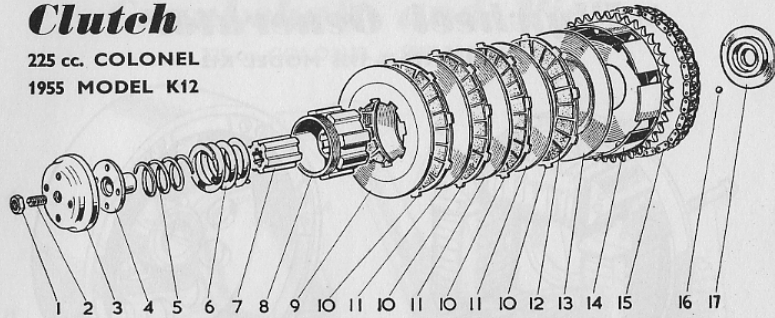

Ill. No.	Description of Part	Qty.	Part No.	Price each £ s. d.
1	Internal clutch adjuster lock nut ...	1	704418	4
2	Clutch adjuster screw internal ...	1	704419	3
3	" cap nut ...	1	704420	6 0
4	" centre nut ...	1	704421	4 0
5	" inner spring ...	1	704422	6
6	" spring ...	1	704423	1 6
7	" hub ...	1	704424	6 0
8	" sliding sleeve ...	1	704425	18 0
9	" pressure plate ...	1	704426	3 6
10	" driving plate ...	4	704427	6 0
11	" intermediate plate ...	3	704428	3 6
12	" corks ...	80	704429	set 5 0
13	" back plate ...	1	704430	6 0
14	" chainwheel assembly ...	1	704431	1 0 0
15	P.D. chain ...	1	704184	*
16	Clutch chainwheel ball track ...	1	704433	3 0
17	Balls for roller track $\frac{3}{16}$ " ...	24	000162	set 1 3

\* Manufacturers current price

# Carburettor

TYPE S.25 — 225 cc. COLONEL — 1955 MODEL K12

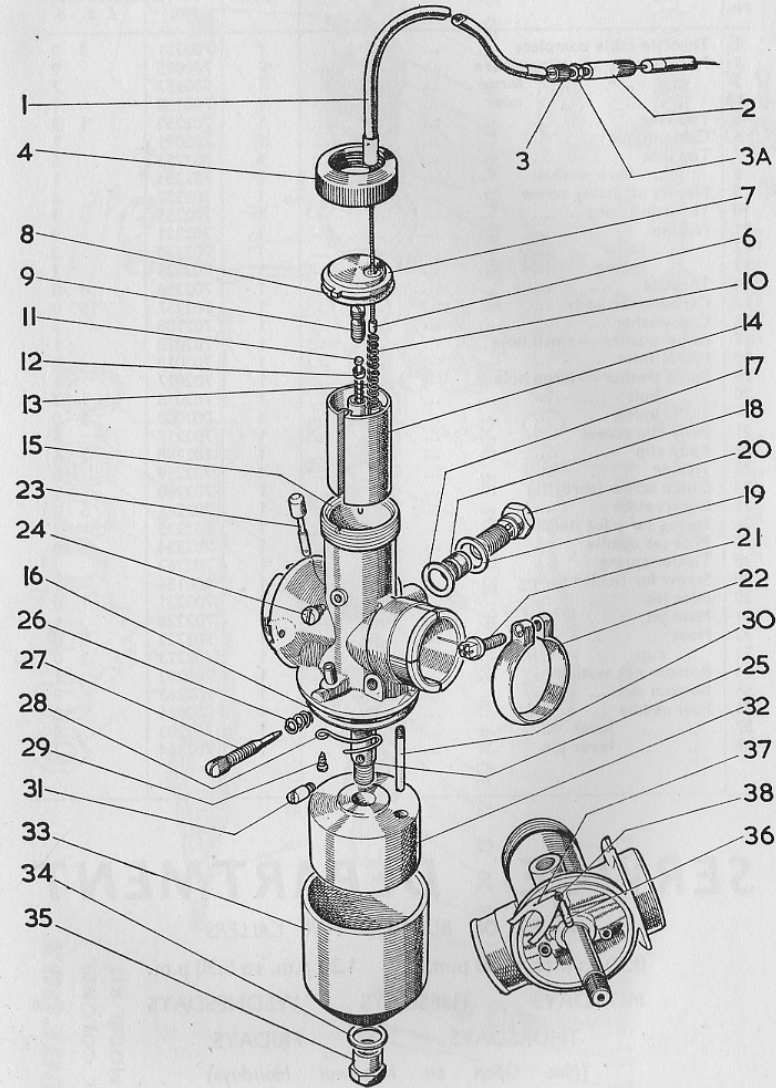

**TYPE S.25 CARBURETTER**  
**225 cc. COLONEL — 1955 MODEL K12**

Ill. No.	Description of Part	Qty.	Part No.	Price each £ s. d.
1	Throttle cable complete ...	1	702251	5 0
2	Middle cable adjusting sleeve ...	1	700095	9
3	" " " screw ...	1	700157	7
3A	" " " nuts ...	1	700158	1
4	Top ring ...	1	702252	1 3
6	Cable nipple ...	1	702091	1
7	Top disc ...	1	702253	6
8	" " fibre washer ...	1	702254	1
9	Needle adjusting screw ...	1	702232	6
10	Throttle spring ...	1	702255	3
11	Needle ...	1	702231	9
12	" collar ...	1	702230	2
13	" spring ...	1	702229	3
14	Throttle ...	1	702256	4 0
15	Carburetter body ...	1	702257	15 3
16	Cup washer ...	1	702108	3
17	Banjo washer — small hole ...	1	702018	1
18	Petrol filter ...	1	702019	8
19	Banjo washer — large hole ...	1	702017	1
20	" bolt ...	1	702016	1 3
20	" union ...	1	002000	2 0
21	Body clip screw ...	1	702217	5
22	Body clip ...	1	702258	2 6
23	Tickler ...	1	702259	6
24	Guide screw (throttle) ...	1	702260	2
25	Centrepiece ...	1	702261	5 0
26	Spring for pilot needle ...	1	702225	2
27	Pilot jet needle ...	1	702224	10
28	Tickler spring ...	1	702262	2
29	Screw for tickler spring ...	1	900155	1
30	Pilot jet ...	1	702221	1 0
31	Main jet ...	1	702226	6
32	Float ...	1	702222	5 0
33	" cup ...	1	702223	3 0
34	Bottom nut washer... ..	1	700282	1
35	Bottom nut ...	1	702263	9
36	Fuel needle ...	1	702021	10
37	" " lever ...	1	702203	8
38	" " lever pin ...	1	702264	2

## SERVICE DEPARTMENT

HOURS OF BUSINESS FOR CALLERS

8.30 a.m. to 12.30 p.m.      1.30 p.m. to 5.30 p.m.

MONDAYS      TUESDAYS      WEDNESDAYS

THURSDAYS      FRIDAYS

(Not Open on National Holidays)

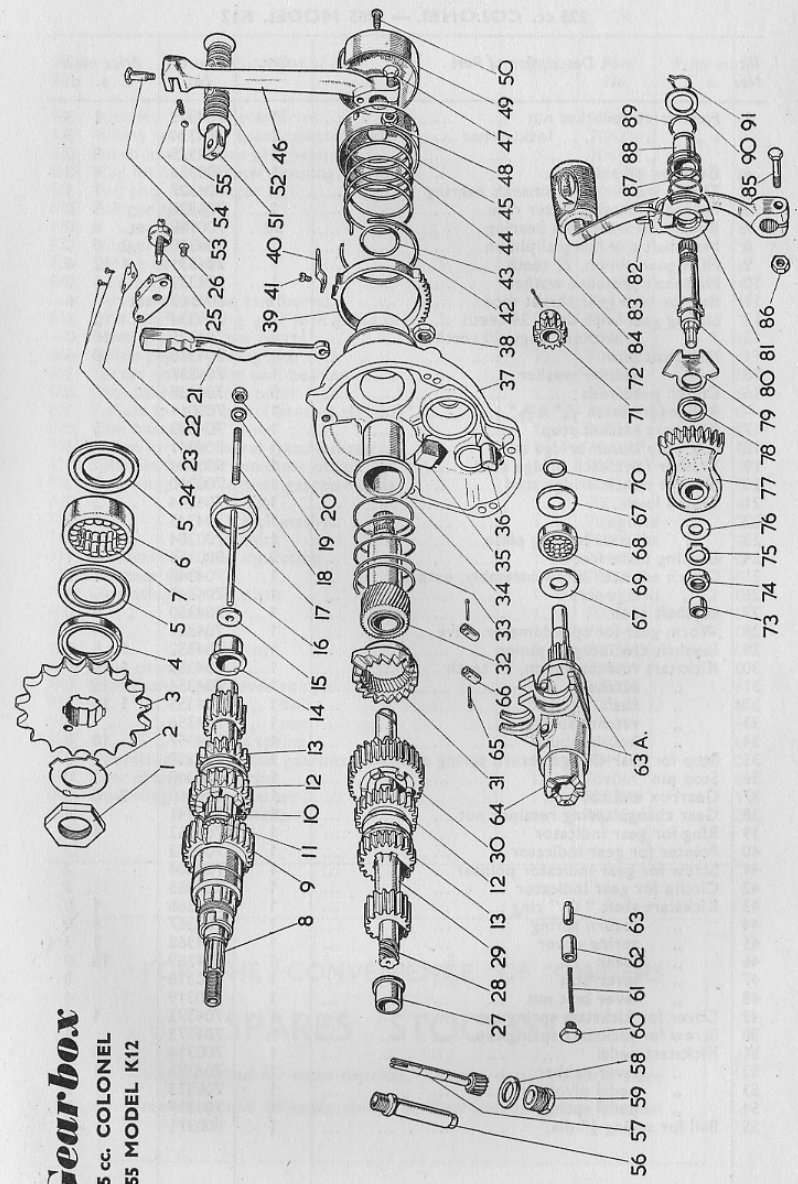

**Gear box**  
 225 cc. COLONEL  
 1955 MODEL K12

**GEARBOX**  
225 cc. COLONEL — 1955 MODEL K12

III. No.	Description of Part	Qty.	Part No.	Price each £ s. d.
1	Final drive sprocket nut ... ..	1	704323	1 3
2	" " " lockwasher ... ..	1	704324	3
3	" " " ... ..	1	704325	8 0
4	Gearbox oil seal ... ..	1	704326	4 0
5	Thrust washer for mainshaft bearing ... ..	2	704327	1 3
6	Mainshaft bearing outer race ... ..	1	704328	5 0
7	Rollers for mainshaft bearing ... ..	38	700188	set 8 0
8	Mainshaft c/w integral pinion ... ..	1	704330	2 0 0
9	High gear pinion, 27 teeth ... ..	1	704331	1 12 6
10	Mainshaft pressure washer ... ..	1	704332	1 0
11	Ball for high gear thrust race ... ..	16	000162	set 6
12	Sliding gear with dogs, 24 teeth ... ..	2	704334	12 6
13	" " without dogs, 20 teeth ... ..	2	704335	10 0
14	Mainshaft bush ... ..	1	704336	8 6
15	" rubber washer ... ..	1	704337	3
16	Clutch push rods ... ..	3	704338	6
17	Roller for clutch $\frac{3}{16}$ " x $\frac{3}{16}$ " ... ..	1	700011	3
18	Kickstart ratchet stop ... ..	1	704340	5 0
19	K.S. stop/clutch bridge stud ... ..	1	704341	3
20	Washer for clutch bridge stud ... ..	1	900004	1
21	Nut for clutch bridge stud ... ..	1	700200	2
22	Clutch lever ... ..	1	704344	3 0
23	" bridge ... ..	1	704345	4 0
24	" adjuster locking plate ... ..	1	700284	3
25	Locking plate screws ... ..	2	900155	1
26	Clutch adjuster screw assembly, external ... ..	1	704348	1 0
27	" bridge screw ... ..	1	704349	3
28	Layshaft bush ... ..	1	704350	6 0
29	Worm gear for speedometer drive ... ..	1	704351	4 0
30	Layshaft c/w integral pinion ... ..	1	704352	1 5 0
31	Kickstart ratchet pinion, 29 teeth ... ..	1	704353	1 10 0
32	" ratchet ... ..	1	704354	15 0
33	" shaft ... ..	1	704355	1 10 6
34	" ratchet spring ... ..	1	704356	4
35	" housing bush ... ..	1	704357	10 0
36	Stop for gear change return spring ... ..	1	704358	2 0
37	Stop pin ... ..	1	700348	2 0
38	Gearbox end cover ... ..	1	704360	2 0 0
39	Gear change spring retainer nut ... ..	1	700341	4
40	Ring for gear indicator ... ..	1	704362	1 6
41	Pointer for gear indicator ... ..	1	704363	3
42	Screw for gear indicator pointer ... ..	1	700204	2
43	Circlip for gear indicator ... ..	1	704365	3
44	Kickstart shaft "O" ring ... ..	1	704366	1 0
45	" return spring ... ..	1	704367	1 0
46	" spring cover ... ..	1	704368	1 3
47	" lever ... ..	1	704369	12 0
48	" lever bolt ... ..	1	700318	8
49	" lever bolt nut ... ..	1	700319	4
50	Cover for kickstart spring cap ... ..	1	704372	1 6
51	Screw for kickstart spring cap ... ..	1	704373	3
52	Kickstart pedal ... ..	1	700314	5 0
53	" lever rubber ... ..	1	704375	1 3
54	" pedal pivot pin ... ..	1	700315	7
55	" pedal spring ... ..	1	700317	1
	Ball for spring $\frac{1}{4}$ " dia. ... ..	1	000371	1

**GEARBOX — continued.**

III. No.	Description of Part	Qty.	Part No.	Price each £ s. d.
56	Bush for speedometer drive ... ..	1	704379	5 0
57	Worm wheel for speedometer drive ... ..	1	704380	4 0
58	Speedometer drive plug washer ... ..	1	704381	2
59	Plug for speedometer housing ... ..	1	704382	1 0
60	End plug for plunger ... ..	1	704383	6
61	Plunger spring ... ..	1	704384	2
62	" bush ... ..	1	704385	1 6
63	Plunger for cam ... ..	1	704386	9
63A	Sliding gear fork ... ..	2	704387	12 6
64	Cam barrel ... ..	1	704388	1 2 6
	Thrust washer for cam barrel ... ..	1	704389	9
65	Split pin for sliding gear fork guide peg ... ..	2	704390	1
	Bearing pin for cam barrel ... ..	1	704391	1 0
66	Guide peg for sliding gear fork ... ..	2	704392	6
67	Thrust washers for cam bearing ... ..	2	704393	1 0
68	Cam barrel bearing outer race ... ..	1	704394	2 6
69	Rollers for cam barrel bearing $\frac{3}{16}$ " x $\frac{3}{16}$ " ... ..	24	700011	set 6 0
70	Cam barrel "O" ring ... ..	1	704396	1 0
71	Pinion for cam barrel (gear indicator) ... ..	1	704397	1 0
72	Split pin for gear indicator pinion $1\frac{3}{8}$ " x $\frac{3}{32}$ " ... ..	1	704398	1
73	Operating spindle bush gearbox body ... ..	1	700235	1 0
74	" nut ... ..	1	700341	4
75	" lock washer ... ..	1	700340	2
76	" shim ... ..	As reqd	700338	2
77	Quadrant for gear operation ... ..	1	704403	8 0
78	Distance piece ... ..	1	700337	5
79	Operating spindle plate ... ..	1	704405	2 0
80	" spindle ... ..	1	700335	14 0
81	" pawl ... ..	1	700342	10 0
82	" pawl spring ... ..	1	700343	1 0
83	Gear change lever ... ..	1	704409	8 0
84	Foot change gear lever rubber ... ..	1	700320	1 6
85	" " " bolt ... ..	1	700318	8
86	" " " nut ... ..	1	700319	4
87	" ratchet spring ... ..	1	700344	6
88	Operating spindle bush gearbox end plate ... ..	1	704414	4 0
89	Gear change "O" ring ... ..	1	704061	8
90	Operating spindle washer ... ..	1	700339	1
91	" circlip ... ..	1	700126	2

**FOR THE CONVENIENCE OF OWNERS  
SPARES STOCKISTS**

are appointed for most districts. To save delay, customers are recommended to apply always to their nearest Spares Stockist

# Lighting

## AC-DC BATTERY RECTIFIER SET 225 cc. COLONEL — 1955 MODEL K12

Description of Part	Qty.	Part No.	Price each £ s. d.
HEADLAMP complete less speedometer ... ..	1	701704	
Fixing bolt, lamp brackets ... ..	2	701531	
Bracket washer ... ..	2	701532	
Sealed beam light unit ... ..	1	701566	
Chromed headlamp rim ... ..	1	701564	
Spring clip (light unit fixing) ... ..	5	701565	
Headlamp rim clip ... ..	1	701701	
"    " screw ... ..	1	701702	
"    " screw ... ..	1	701568	
Main bulb adaptor ... ..	1	701699	
Pilot bulb adaptor with lead ... ..	1	701642	
Main bulb 6 v. 24/24 w. pre-focus ... ..	1	701636	
Pilot bulb 6 v. 3 w. ... ..	1	701573	
Switch complete ... ..	1	701519	
" spring clip ... ..	1	701520	
" rubber ring ... ..	1	701559	
" handle ... ..	1	701560	
" centre screw ... ..	1	701693	
Wiring harness complete ... ..	1	701700	
"    " rubber grommet ... ..	1	002499	
Cable connector ... ..	1	000586	
Dipswitch and horn button ... ..	1	701516	
Ammeter ... ..	1	701517	
Rubber ring for ammeter ... ..	1	003069	
Beading, headlamp ... ..	1	002674	
TAIL LAMP complete ... ..	1	701679	
Rubber moulding ... ..	1	701680	
Back plate ... ..	1	701681	
Bulb holder ... ..	1	701682	
Lead assembly ... ..	3	701683	
Backplate fixing screw ... ..	3	701684	
Shakeproof washer ... ..	3	701685	
Hex nut ... ..	1	701686	
Red plastic lens ... ..	2	701687	
Lens fixing screws ... ..	2	701688	
Rubber washers ... ..	1	701689	
White plastic window ... ..	1	701638	
Bulb, 6 volt 18/3 watt. ... ..	1	000463	
RECTIFIER and cables ... ..	4	900165	
Bolt, $\frac{3}{8}$ " x 26 t.p.i. ... ..	4	000465	
Insulator ... ..	4	900168	
Fibre washer ... ..	4	900006	
Shakeproof washer ... ..	4	900016	
Hex nut $\frac{3}{8}$ " x 26 t.p.i. ... ..	4	900016	
BATTERY, Lucas type PUZ7E-9 ... ..	1	002835	
HORN, complete with bracket... ..	1	003161	
Cable terminal ... ..	—	002706	

NOTE : Prices of electrical equipment available upon application.

## ADDITIONAL EQUIPMENT

Description of Part	Qty.	Part No.	Price each £ s. d.
Pillion footrests complete ... ..	2	—	pr. 8 0
Footrest hanger ... ..	2	002203	1 9
Rubber ... ..	2	002204	1 9
Pannier frame, L.H. ... ..	1	002704	1 1 0
Pannier frame, R.H. ... ..	1	002705	1 1 0
Hex bolt $\frac{5}{16}$ " x 26 x 3 $\frac{3}{4}$ " long ... ..	2	900355	5
Spacer $\frac{1}{2}$ " dia. x 16 swg x $\frac{3}{8}$ " long ... ..	2	002826	3
Stop light set ... ..	1	002783	10 6
Pannier bags ... ..	2	002474	pr. 1 16 9*
Safety bar and leg shield complete ... ..	1	003200	2 12 6
Windscreen ... ..	1	001411	1 11 6
Rear view mirror ... ..	1	002782	7 6
Licence holder ... ..	1	001966	3 0
Licence holder glass ... ..	1	001966G	6
Bulb horn ... ..	1	000605	5 0
Lapel badge ... ..	—	—	1 3
Instruction book ... ..	—	—	3 0

\* Purchase Tax on pannier bags 13/9.

FROM CITY CENTRE NO 8 BUS STOP (INNER CIRCLE)

JAMES SERVICE DEPT

NO 29,29A BUS TO CITY

NO 44 BUS STOP

MERMAID INN

NO 44 BUS STOP TO CITY

NO 29,29A,36 BUS STOP FROM CITY

NO 44,44A,44B BUS STOP FROM CITY

TRAFFIC LIGHTS

Dealers or private owners of James machines calling at the factory are requested to make an appointment by letter or telephone. This will avoid unnecessary waiting and ensure prompt attention to enquiries.

**JAMES MOTOR CYCLES LIMITED**  
BIRMINGHAM, 11

## GUARANTEE

We give the following guarantee with our motor cycles, motor cycle combinations and sidecars, including all accessories and component parts other than tyres, saddles, chains and lighting and electrical equipment, and other than accessories and component parts supplied to the order of the Purchaser and differing from those comprised in the standard specifications supplied with our motor cycles, motor cycle combinations and sidecars, but including accessories and parts supplied by way of exchange as hereinafter provided. This guarantee is given in place of any implied conditions or warranties or any liabilities whatsoever statutory or otherwise; no guarantee except that hereinafter contained and no conditions or warranty whatsoever statutory or otherwise is given or is to be implied, nor are we to be under any liability whatsoever except under the guarantee hereinafter contained. Any statement, description, condition or representation contained in any catalogue, advertisement, leaflet or other publication shall not be constructed as enlarging, varying or overriding anything herein contained. In the case of machines (a) which have been used for "hiring out" purposes or (b) any motor cycle and/or sidecar used for any dirt track, cinder track or grass track racing or competitions (or any competition of any kind within an enclosure for which a charge is made for admission to take part in or view the competition) or (c) machines from which the trade mark, name or manufacturing number has been altered or removed or (d) any machines in which parts have been used not supplied by or approved by the motor cycle manufacturer or (e) any machine from which the silencing system as fitted by the manufacturer has been partially or wholly removed or interfered with, no guarantee, condition or warranty of any kind statutory or otherwise, is given or is to be implied, nor are we to be under any liability whatsoever in respect of any such machine. We guarantee, subject to the conditions mentioned below, that all precautions which are usual and reasonable have been taken by us to secure excellence of materials and workmanship, but this guarantee is to extend and be in force for six months only in U.K. and ninety days overseas from date of purchase, or date of exchange in case of any accessory or part supplied by way of exchange as hereinafter provided, and damages for which we make ourselves responsible under this guarantee are limited to the free repair or supply of a new part or accessory in exchange for the part of the motor cycle, motor cycle combination or sidecar or accessory which may have proved defective. We undertake, subject to the conditions mentioned below, to make good in manner aforesaid any part or accessory covered by this guarantee which has proved defective within the said period. We do not undertake to replace or refix or bear the cost of replacing or refixing any such new part or accessory in the motor cycle, motor cycle combination or sidecar. As motor cycles, motor cycle combinations and sidecars are easily liable to derangement by neglect or misuse, this guarantee does not apply to defects caused by wear and tear, misuse or neglect.

The term "misuse" shall include, amongst others, the following acts :

1. The attaching of a sidecar to a motor cycle in such a manner as to cause damage or calculated to render the latter unsafe when ridden.
2. The use of a motor cycle or of a motor cycle and sidecar combined, when carrying more persons or a greater weight than for which the machine was designed by the manufacturers.
3. The attaching of a sidecar to a motor cycle by any form of attachment not provided, supplied or approved by the manufacturers, or to a motor cycle which is not designed for such use.

We do not guarantee tyres, saddles, chains or lighting and electrical equipment, or any accessories or component parts supplied to the order of the Purchaser differing from those comprised in the standard specifications supplied with our motor cycles, motor cycle combinations or sidecars. As regards all such tyres, saddles, chains, lighting and electrical equipment, accessories and component parts, no guarantee, condition or warranty of any kind statutory or otherwise is given or is to be implied, and we are to be under no liability whatsoever in respect thereof.

**CONDITIONS OF GUARANTEE**—If a defective part or accessory should be found in our motor cycles, motor cycle combinations or sidecars, or in any part or accessory supplied by way of exchange as before provided, it must be sent to us **CARRIAGE PAID** and accompanied by an intimation from the owner that he desires to have it repaired or exchanged free of charge under our guarantee, and he must also furnish us at the same time with the frame number of the machine, the date of purchase or the date when the alleged defective part or accessory was exchanged as the case may be.

Failing compliance with the above, such articles will lie here at **THE RISK OF THE OWNER**, and this guarantee and any implied guarantee, warranty or condition shall not be enforceable.

**REPAIRS**—Any motor cycle, motor cycle combination or sidecar sent to us to be plated, enamelled or repaired will be repaired upon the following conditions, *i.e.*, we guarantee that all precautions which are usual and reasonable have been taken by us to secure excellence of materials and workmanship, such guarantee to extend and be in force for three months only from the time such work shall have been executed, and this guarantee is in lieu and in exclusion of all conditions and warranties statutory or otherwise, and all liabilities whatsoever and the damages recoverable are limited to the cost of any further work which may be necessary to amend and make good the work found to be defective.

**NOTE**—We do not appoint agents for the sale on our behalf of our motor cycles or other goods, but we assign to motor cycle Dealers areas in which we supply to such Dealers exclusively for re-sale in such areas. No such Dealer is authorised to transact any business, give any warranty, make any representation or incur any liability on our behalf. Published retail prices are for delivery free of charge at Dealers' premises. All goods are offered for sale subject to the price ruling at the time of delivery. All prices and specifications are subject to alteration without notice.



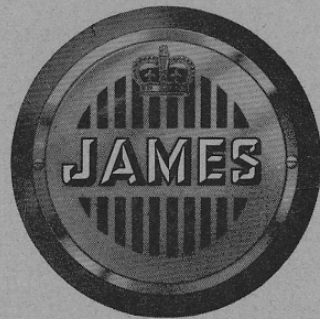

James Publication No. S12/55/2M  
June, 1955

PRINTED IN ENGLAND