

OPERATING INSTRUCTIONS
AND
SPARE PARTS LIST



MARK 1F
TWO STROKE
MOTOR CYCLE ENGINE GEAR UNIT



TWO SHILLINGS
AND SIXPENCE

THE VILLIERS ENGINEERING CO. LTD.
WOLVERHAMPTON, ENGLAND.

Telegrams:
" VILLIERS "
WOLVERHAMPTON.

Telephone:
WOLVERHAMPTON 2 2 3 9 9
(20 lines) All departments.

THE *Villiers* Mk. 1F

ENGINE-GEAR UNIT

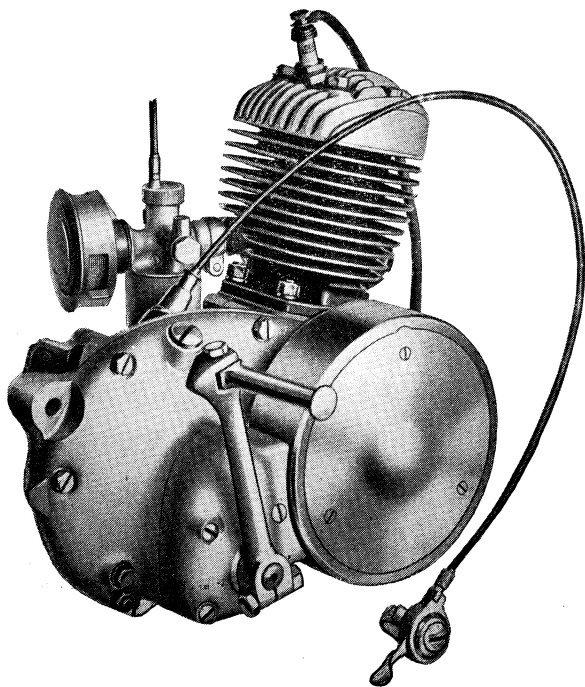

**BEFORE ATTEMPTING TO START ENGINE
CAREFULLY READ INSTRUCTIONS ON PAGES 3 & 4.**

The VILLIERS Mk. I.F. ENGINE-GEAR UNIT

SPECIFICATION.

The Mark I.F. Unit consists of a 98 c.c. Two-stroke Engine and two speed gearbox built as one assembly, the drive from engine crankshaft to clutch on gearbox mainshaft being by an endless roller type chain running in an oil bath case.

A deeply finned cast iron cylinder with one exhaust and two transfer ports of unique design is used, the carburetter being mounted on a stub at the rear.

Secured to the cylinder by four bolts is an aluminium alloy head in which is fitted a 14 mm. sparking plug (Lodge H.14). The aluminium flat topped piston carries a floating gudgeon pin located endways by circlips. The "big end" bearing consists of two rows of steel rollers running on a crankpin fitted in double crankwebs carried by a large ball journal bearing on each side.

Power is taken through a two plate cork insert clutch, control being by Bowden cable and lever fitted on cycle handlebar.

Final drive to rear wheel is by a roller chain. A Villiers Junior pattern carburetter is fitted at the rear of cylinder, control being by a single lever. A combined air filter with strangler for easy starting and within the reach of the rider is standard equipment.

The two speed gear is of the sliding dog type, there being a neutral or free engine position between high and low gear, gear control being by Bowden cable, operated by a lever on handlebar.

A kickstarter is provided as an integral part of the gearbox, the kickstart lever being fitted with a pedal which folds back out of the way when not in use.

As with all our engines, the Villiers flywheel magneto provides the high tension current for ignition, but for the Mark I.F. model a special magneto providing independent ignition and lighting has been developed. This magneto has lighting coils built in, giving alternating current which is rectified by a Westinghouse Rectifier for charging a 6-Volt—10-amp./hr. battery.

The rectifier is hermetically sealed, and can be fitted to any part of the cycle frame providing metal to metal contact is made with the outer plate of the rectifier, which is the EARTH connection of the circuit

The standard lighting bulbs are used as follows:—

Head 6-V.—12/12W.

Pilot and Tail 6-V.—3W.

See overleaf for BULBS for DIRECT LIGHTING SET.

GENERAL DATA.

Engine Unit	Model Mk. 1.F.
Bore	47 mm. = 1.8504 inches.
Stroke	57 mm. = 2.244 ..
Capacity	98 c.c. = 6 cubic inches.
Horse Power, Maximum ...	2.8 at 4,000 r.p.m.
Engine Sprocket	17 teeth, $\frac{3}{8}$ inch pitch.
Clutch Sprocket	42
Ratio, Engine to Clutch ...	2.47—1.
Gear Box Ratios	1.64—1 and 1—1.
Final Drive Sprocket ...	14 teeth, $\frac{1}{2}$ inch pitch for "COVENTRY" chain No. 112045.
Chain Line, Final Drive ...	2 $\frac{1}{2}$ inches.
Final Gear Ratio	Top 8.47—1, bottom 13.89—1 with rear wheel sprocket having 48 Teeth, Tyre size 25 inches.
Exhaust Pipe	1 $\frac{1}{4}$ inch external diameter.
Sparking Plug	14 mm. Lodge H14; point gap .018" to .025".
Carburetter	Villiers "Junior" type 6/0.
Carburetter Jet Size ...	No. 8 Type 6/0, No. 120 on later engines.
Carburetter Taper Needle ...	No. 2 $\frac{1}{2}$ Type 6/0.
Ignition Timing	$\frac{1}{8}$ " before Top Dead Centre.
Contact Breaker	Point gap .015" maximum.
Lighting Set (Rectifier) ...	Head Lamp. Main Bulb. 6-Volt— 12/12 Watt S.B.C. Pilot Bulb. 6-Volt—3 Watt Miniature Bayonet Cap. Tail Lamp Bulb. Double Filament S.B.C. 6-Volt—3 Watts/6-Volt—18 Watts Stop Light.
Lighting Set (Direct) ...	Headlamp Bulb 6v. 18/18 Watt D/C. Pilot Bulb 3.5 volt .15 amp M.E.S. Tail Lamp Bulb 6 volt 3 Watt S.C.
Lubrication, Engine ...	Petrol mixture in fuel tank (See Page 3).
Lubrication, Gearbox and Chaincase	Castrol D (S.A.E. 140) filled to level level plug. (See Fig. 1).

INSTRUCTIONS FOR USING THE VILLIERS MARK 1.F. UNIT.

BEFORE USE.

GEARBOX AND CHAINCASE.

Remove the gearbox oil filler and oil level plugs, see Fig. 1 and with the cycle off the stand, pour in CASTROL D (S.A.E.140) until it runs out at the level plug hole. Refit plugs securely. Examine every 500 miles and top up if necessary.

FUEL TANK

Fill up Tank with a mixture of oil and petrol, the mixture to be made and well shaken before putting into Tank.

We recommend "Castrol" two-stroke Self-Mixing Oil at a ratio of $\frac{1}{2}$ -pint to one gallon of petrol (ratio 1-16) OR Castrol XL Oil (S.A.E. 30) ratio 1-20.

Due to the Self-Mixing properties of "Castrol" two-stroke Self-Mixing Oil, $\frac{1}{2}$ -pint to one gallon of petrol represents a ratio of 1-20 actual lubricant to petrol, and **no pre-mixing is necessary**, but it is essential to turn off the Petrol Tap and put the oil into the Tank before the petrol.

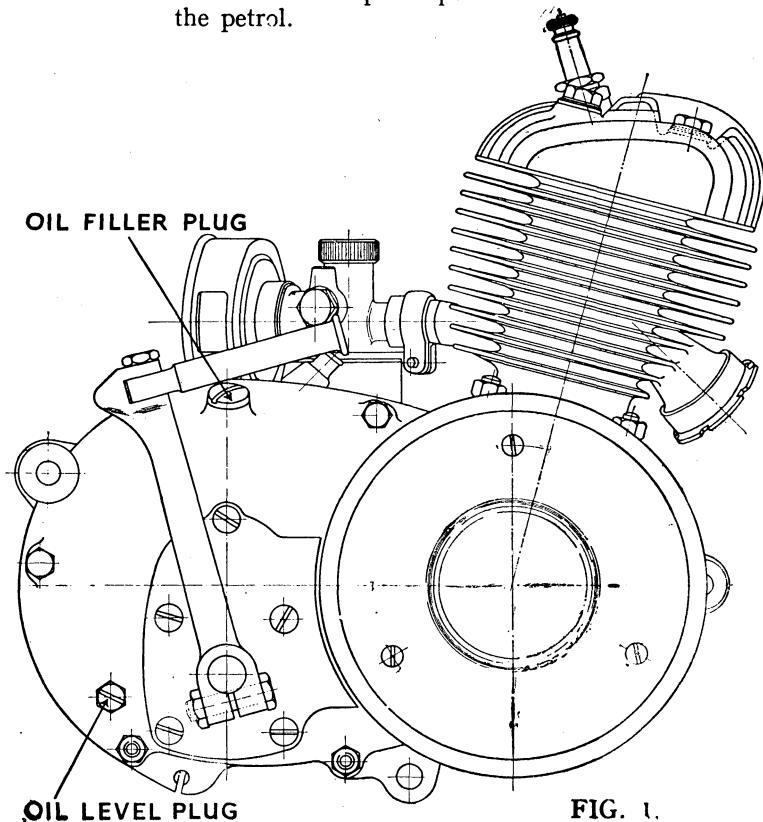

GEAR CONTROL.

The gear positions are controlled by hand through a "Bowden" cable, the control unit being clipped to the right hand handlebar. Top, or high gear is obtained by moving the hand lever inwards, or to the left towards rider, as far as possible to the position marked H on the cover plate of control unit. To give the bottom, or low gear, the lever is moved over as far as possible to the right, and half-way between the "LOW" and "HIGH" is the neutral or free engine position.

STARTING THE ENGINE.

Before starting the engine make sure that the Battery is connected, or Rectifier disconnected if Battery is not in use.

WHEN COLD. Turn petrol tap to the ON position. Turn strangler shutter so as to close the air slots. Open throttle lever inwards about one third of the full movement, then flood carburetter by depressing the tickler.

If the back wheel is on the ground, but the gear control lever into the neutral position, this operation being made easier if the machine is moved to and fro at the same time.

A firm push or two on the starter pedal should start the engine, and as engine warms up the strangler shutter should gradually be moved round its fully open position. In very cold weather it may not be possible to do this immediately in which case leave partly closed until engine is warmed up.

WHEN HOT. As above, but do not flood carburetter or close strangler.

FAILURE TO START. If the engine will not start after a reasonable number of attempts, ascertain if this is due to lack of compression, no fuel or faulty ignition. COMPRESSION should be felt whilst rotating the engine by the kickstarter, with the throttle partly open.

FUEL SUPPLY. Depress tickler at side of carburetter body. If fuel is reaching float chamber, it will spurt from vent hole in tickler cap.

FAULTY IGNITION. Unscrew spark plug from cylinder head and with the ignition cable attached place on a flat metal part of engine. When the engine is rotated a spark should be visible at the points. If no spark, detach cable and hold end one-eighth inch from cylinder whilst rotating engine.

If these preliminary tests prove negative a more detailed examination will have to be made, and reference should be made to "Tracing Engine Troubles" on pages 13-17.

ON THE ROAD.

Having started and warmed up the engine, sit astride the machine, and with both feet on the ground free the clutch by pulling up the control lever, which is usually fitted on the left handlebar. At the same time, with the right hand move the gear control lever outwards to the "LOW" gear position, and if necessary move the machine along so as to allow the SLIDING DOG CLUTCH in gearcase to fully engage with the LOW GEAR WHEEL. Slowly release the clutch lever and as the machine moves forward open the throttle to prevent the engine stalling whilst taking up the drive through the clutch. When a speed of about 12 miles an hour has been reached, the clutch lever should be raised, and the throttle almost closed simultaneously, then with the clutch disengaged move the gear lever inwards to the "HIGH" gear position, and immediately this has been done release clutch lever and open up throttle control. When changing down to the "LOW" gear, disengage the clutch and regulate the throttle control to give an engine speed in step with the low gear ratio. Do not hang on to top gear too long when hill climbing, and do not control the road speed by slipping the clutch, except when travelling very slowly in traffic.

RUNNING IN.

For the first 500 miles the engine must not be over-driven, and during this period the throttle should not be fully opened. The engine must not be allowed to race, or run at a high speed under a light load. Do not exceed the following speeds until after 500 miles have been run, Low Gear—12 m.p.h. High Gear—20 m.p.h. After covering the first 500 miles the road speed can be gradually increased, but when hill climbing, change to the low gear before allowing the engine to labour in top gear. When the "running in" mileage has been completed, it will be very likely necessary to weaken off the mixture by lowering slightly the taper needle in carburetter, how to do this is explained in the section dealing with the carburetter.

ROUTINE ATTENTION.

It is advisable, in order to enjoy trouble-free riding, that the engine and machine should have periodical attention, and the following hints will help to keep the engine in good running order:—

EVERY 500 MILES inspect level of oil in gearcase by removing Level Screw (See Fig. 1) at rear of kickstarter housing. Top up if necessary with grade of oil previously recommended.

AFTER THE FIRST 500 MILES HAVE BEEN COMPLETED examine the contact breaker points, as they may require slight adjustment after initial bedding in. The correct gap when points are fully open is .015". They should also be kept free from oil.

EVERY 2,000 MILES remove cylinder head and scrape out carbon. The edges of the exhaust port in the cylinder can be cleaned when the piston is at the bottom of the stroke. Clean piston top.

It should not be necessary to remove barrel and piston every 2,000 miles every 4,000 miles should be sufficient

EVERY 2,000 MILES remove and clean silencer and exhaust pipe.

EVERY 4,000 MILES remove and wash out air cleaner with petrol.

Leave to dry, dip into thin oil and leave to drain before replacing.

OCCASIONALLY CHECK CLUTCH CONTROL CABLE ADJUSTMENT. There should be a very small amount of slack in the clutch cable when clutch is engaged, ($\frac{1}{16}$ " to $\frac{1}{8}$ "). Adjust clutch cable by means of adjustment screw on clutch bridge casting. Screw the adjuster in until there is just a trace of slack in the cable; this is essential, otherwise the clutch may be slightly disengaged and cause slipping. Tighten locknut after adjustment. When engine is new, fairly frequent adjustment will be necessary owing to bedding down of clutch corks.

Insufficient slack movement in the clutch cable, or riding with one hand on the clutch lever, will also cause rapid push rod wear. Occasionally examine joints, cylinder head, cylinder base, crankcase and clutchcase for gas or oil leaks and tighten if necessary. Examine all visible nuts, bolts and screws for looseness.

GEAR CONTROL CABLE ADJUSTMENT.

It is vitally important that the gear control cable is always maintained in correct adjustment, otherwise the gears will be damaged and expensive replacements will be necessary. The adjustment is correct when there is a small amount of slack movement ($\frac{1}{16}$ " to $\frac{1}{8}$ ") in the cable **WHEN THE GEAR CONTROL LEVER IS IN THE TOP GEAR POSITION.** This degree of slack movement will ensure that top gear is fully engaged, and a spring helps to hold the gears in "top." If the slack movement in the cable is greater than $\frac{1}{8}$ ", bottom gear will not fully engage and the result will be damage to the engaging dogs.

There is a cable adjuster incorporated in the gear change cable, and this adjuster is situated roughly midway along the cable between the handlebars and the gearbox. Should the range of this midway adjuster be insufficient to give correct adjustment, there is a further adjuster screwed into the handlebar mounted gear control body.

The screw on the top of the gear control lever assembly must be kept tightened down sufficiently to ensure that the amount of friction in the control will prevent bottom gear jumping out of engagement. If bottom gear does jump out of engagement, it will be because the cable adjustment is not correct or because there is not enough friction in the operation

of the gear control. If these adjustments are correct but bottom gear still jumps out of engagement this indicates that the engine has been running with incorrect cable and control adjustments resulting in damage to the gears.

NOTE.

When engaging bottom gear with the machine stationary, any tendency towards "snatching," will be much reduced if the clutch lever is pulled right up to the handlebar and the engine is running at a slow tick-over speed.

CARBURETTER.

The Villiers Junior Carburetter type 6/0 is used with the Mark 1.F. Engine and it should not be necessary to alter the setting obtained by the maker after road testing the machine.

OPERATION OF CARBURETTER.

The function of the Carburetter is to supply a mixture of petrol and air in correct proportion under all conditions. In the Villiers Carburetter the float chamber surrounds the jet and centrepiece, and in the chamber an annular float rises as the fuel enters the chamber until the correct level is obtained, then the forked lever which rests on the top of the float lifts the fuel needle which has a conical end and shuts off the fuel supply by closing the hole in the bush fitted in carburetter body.

Fuel enters the centrepiece through a hole in the side and passes through the calibrated jet fitted in the bottom of centrepiece. The centrepiece and jet cannot be supplied separately and should never be taken apart as if they are separated they become scrap owing to distortion.

The throttle operated by the cable is fitted with a taper needle which extends below the throttle and into the centrepiece. When the throttle slide closes the air supply the largest diameter of the needle nearly closes the fuel outlet, but when the slide is lifted admitting more air, the smaller diameter of the needle now in the centrepiece allows more fuel to pass. A suitable combination jet size, needle position and taper will give a correct mixture strength on all throttle openings.

The fuel level is maintained by a float and needle valve, and under no circumstances should any alteration be made either to the above or to the float lever. The lever should have up and down movement on its retaining pin, and when the float is held up against the float lever, the distance between the top of the float and the underside of the carburetter body should be $\frac{1}{32}$ ".

The amount of fuel supplied to the engine is controlled by one jet which is fixed in the bottom of the centrepiece, and by the taper needle which is carried in the throttle and operates in the top end of the centrepiece.

The Carburetter is automatic in action and gives a correct mixture over the whole range of throttle openings, the only available adjustment being the position of the taper needle in the throttle (which controls the size of the jet orifice). It is not possible to quote a standard position for the needle in relation to the throttle because an individual adjustment is necessary for each engine.

The needle controls the mixture strength from tickover to approximately two-thirds throttle, the jet controls the remainder. No alternative sizes of needles and jets are available, nor are they necessary for normal conditions.

The position of the taper needle in the throttle is determined during testing at the works, but should it be necessary to alter the setting this is done by the needle adjusting screw situated in the centre and top of throttle. Screw in to weaken mixture, (i.e. lower needle), the screw should not be loose in the throttle slide as it is likely to move and alter the setting. It is split to make it grip the hole. Should the screw be loose the split portion should be gently prised apart before fitting.

NOTE.—The taper needle spring should be fitted with the small coil end of the spring under the head of needle.

ALWAYS STOP ENGINE BEFORE ATTEMPTING TO ADJUST NEEDLE.

TO DISMANTLE CARBURETTER.

TO REMOVE THROTTLE FROM BODY. Open throttle to full open, undo top ring, throttle can now be withdrawn. Take care not to damage or bend the taper needle. Return throttle to fully closed position, the guide peg attached to top disc will then be exposed and, if necessary, the control cable can be detached by compressing throttle spring, the inner cable then being lifted out through the slot.

TO REMOVE CENTREPIECE AND FUEL NEEDLE. Unscrew the bottom nut underneath the float chamber cup. Next remove the fibre washer, the cup with float inside, and if loose, the fibre washer between cup and carburetter body. Then remove the small centrepiece locking screw situated below and to the rear of the banjo petrol pipe union, the centrepiece with fibre washer under head can now be pushed up through the throttle bore.

When the centrepiece is removed the fuel needle lever can swing round and will thus allow the fuel needle to drop out of its seating; the needle should therefore be removed at the same time as the centrepiece and kept in a safe place until required for reassembly. No attempt should be made to remove the fuel needle lever from the carburetter body.

TO REMOVE TICKLER. This should not be necessary unless the vent hole in base of body is blocked, in which case remove the split cotter pin at end of tickler which will release the tickler and its spring. One vent hole is at the bottom of the hole where the spring fits, the other being in the side of the tickler cap.

CARBURETTER SETTING. The Carburetter is fitted with a taper needle marked $2\frac{1}{2}$ on the parallel portion under the head, a centrepiece marked J8 on the head, and the jet (which is not detachable) marked 8 on the hexagon portion. Some engines have these parts marked V120 instead. The normal taper needle setting is $\frac{3}{32}$ " from the bottom of the throttle to the end of the needle, but this is usually a matter of individual adjustment to suit each engine, and the above dimension should only be regarded as a guide.

The best setting of the taper needle is that which gives the most even two-stroking when the engine has attained its usual running temperature and is running at normal loads and speeds. If the engine four-strokes when pulling very hard, this indicates that the mixture is too rich. Check that the carburetter is not flooding and that the air cleaner is not choked. If the four-stroking continues, lower the taper needle a little to give a weaker mixture. A rich mixture may cause the sparking plug to oil up.

REASSEMBLY OF CARBURETTER. This, of course, is the reverse process to that already described; the fuel needle should be fitted point first, the fuel needle lever should then be placed so that it holds the needle in position whilst the centrepiece is replaced. Care should be taken to see that the centrepiece complete with fibre washer is fitted so that the locking screw locates in the slot in the head of the centrepiece. When refitting float do not overtighten bottom nut as this may distort the jet.

FLYWHEEL MAGNETO AND LIGHTING SETS.

The Villiers 6-Pole Flywheel Magneto provides current for both ignition and lighting. The Alternating Current from the lighting coils is converted to Direct Current by passing through a Selenium type Rectifier and is then used for charging a 6-Volt—10 amp./hr. Battery on the standard MK. IF Lighting Set.

The Rectifier is hermetically sealed and can be fitted to any part of the cycle frame providing metal to metal contact is made with the outer plate of the Rectifier which is the Earth connection of the circuit.

The wiring connections between Battery and Rectifier and Rectifier and Magneto are shown on the diagram FIG. 2.

Note that the POSITIVE side of the battery is EARTHED.

It should be noted that the output from the generator does not quite balance the load on the battery when the headlight is on, and an electric horn and stop light if fitted are additional loads. Therefore some day-light riding is necessary to keep the battery in a charged condition without recourse to charging from an external source of supply. Always make sure that the stop tail lamp bulb is fitted the right way round so that the 18 watt filament lights when the footbrake pedal is operated and the 3 watt filament operates on the normal driving or parking circuits, otherwise the battery will rapidly become discharged.

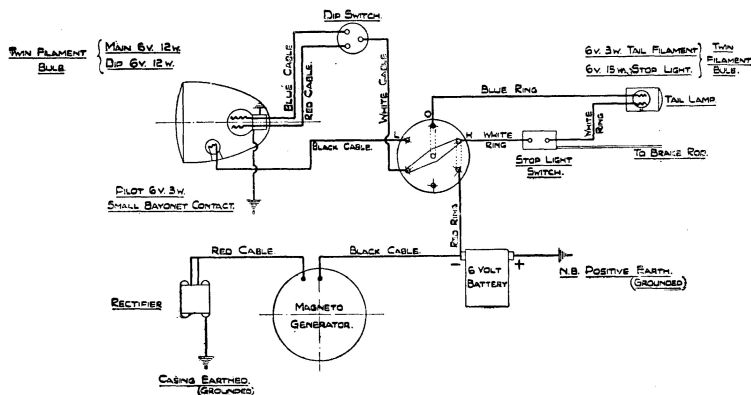

FIG. 2.

IMPORTANT.

Should it be necessary to use the machine whilst the battery is removed the lead running from the magneto to the rectifier **MUST** be disconnected

CARE OF BATTERY.

Once a month unscrew filler caps of each cell and pour in a small quantity of distilled water to bring the acid level with the tops of the separators. Acid should not be added unless this is accidentally spilled out of the battery. This should be replaced by diluted sulphuric acid of the same specific gravity as in the cells. Keep the battery terminals clean.

Many lighting troubles can be traced to unseen corrosion between the surfaces of a perfectly tight joint, and in the case of the battery this corrosion takes place much more frequently than at other electrical contacts. For any further information in connection with battery maintenance, see the special instructions issued by and obtainable from the makers of the battery.

A number of Mk. 1F engines have been supplied with direct lighting sets, in which the Alternating Current from the magneto generator is taken direct to the lamps via the headlamp switch and provision is made in the headlamp shell for a small dry battery (type Ever-Ready No. 800, obtainable from any cycle shop) to supply current for the parking lights.

The wiring diagram for this lighting set is given in Fig. 3, and it should be noted that it is not possible to convert a "Direct" lighting set into a "Rectifier" type as an entirely different lighting set is used.

SEE GENERAL DATA, PAGE 2, FOR CORRECT BULBS FOR EACH OF THESE LIGHTING SETS.

The armature plate which carries the ignition coil, lighting coils, and contact breaker mechanism is secured to the engine crankcase by four screws. The H.T. Lead from ignition coil to sparking plug is detachable by unscrewing from armature plate and when refitting it is important to make sure that the brass pad carried by the spring and secured to the terminal makes contact with the soldered disc on the outside of the ignition coil.

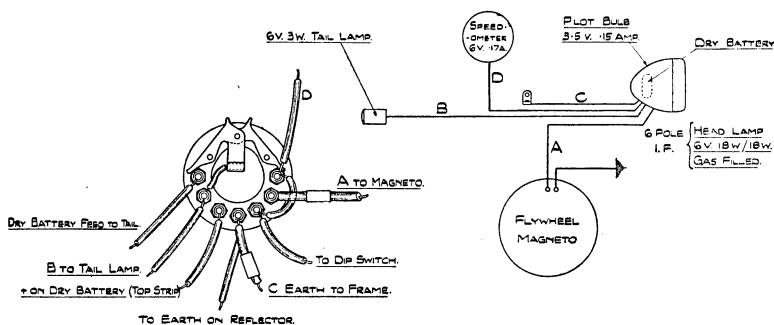

FIG. 3.

In the magneto flywheel are fitted four permanent magnets and two dummies, and it is very important should these be removed at any time that they are replaced in the original position in relation to the peak of the cam profile ground on the centre boss which is rivetted to the arms

of the flywheel. Actually, there is seldom any need to remove any of the parts from the flywheel, and none of the component parts are ever supplied separately as spares.

CONTACT BREAKER ASSEMBLY.

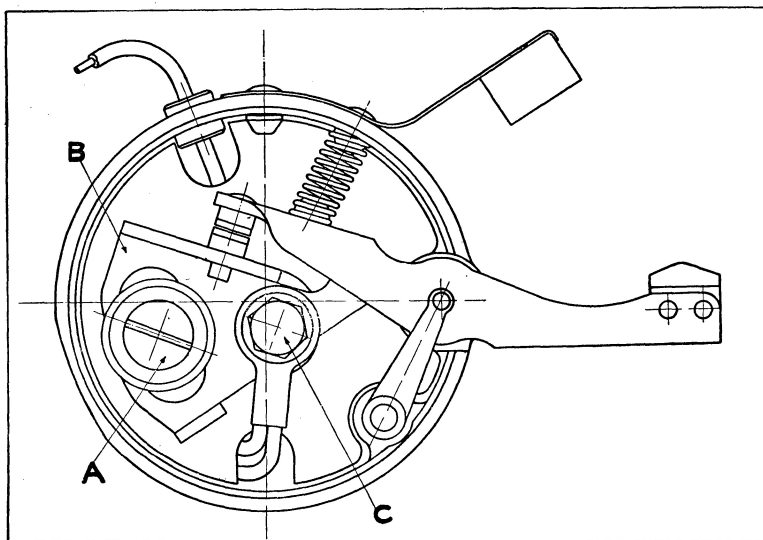

FIG. 4. CONTACT BREAKER ASSEMBLY.

Adjustment.

Turn flywheel until rocker arm point is in the highest position. Release the screw "A," see illustration, Fig. 4.

Position Bracket "B" with .015" feeler gauge between contact points, tighten screw, taking care not to use too much force. It is not necessary to disturb screw "C" when adjusting point gap.

A felt pad is used to keep the cam in a slightly oily condition, and is impregnated when new with grease. This can, if visibly dry, be oiled with a small amount of the heaviest oil available. It is better, however, to soak the pad in a molten high temperature grease if it is convenient to detach the box itself for this operation. If too much oil is put on the felt pad it may creep along the Rocker Arm, get on the contact points and so cause ignition trouble.

The flywheel should not be removed unless absolutely necessary, and then it is advisable to use a Villiers hammer tight Spanner for the centre nut. The nut is imprisoned in the flywheel and acts as an extractor when turned anti-clockwise looking at the Magneto.

Before access can be made to the nut, of course, the flywheel cover has first to be removed by releasing the three screws holding cover to flywheel.

See page 34 for details of latest type of contact breaker assembly.

TIMING OF THE MAGNETO.

The contact breaker points should commence to open when the piston is $\frac{1}{8}$ " before top of stroke. Timing marks are stamped on both the armature plate and flywheel rim.

The mark on the armature plate is stamped on a small boss on the rim of the armature plate, and the mark on the flywheel rim coincides with this mark when the piston is at the top of the stroke. On checking timing it is only necessary to remove the sparking plug; turn flywheel until the two marks are opposite when the piston should be at top of stroke.

When timing ignition after dismantling loosely fit the flywheel to shaft and, having set piston $\frac{1}{8}$ " from top of stroke, rotate flywheel without turning the crankshaft until the contact points commence to open. Tighten up flywheel centre nut sufficiently tight for crankshaft to be rotated. Check to see that the flywheel has not slipped. Finally tighten the centre nut with the special hammer tight spanner, refit cover and screws. Always set contact breaker points to 0.15 ins. gap before timing the magneto, because alteration of the point gap alters the ignition timing.

TRACING TROUBLES.

For the satisfactory running of any Villiers Engine it is essential that three main conditions are fulfilled, and by making a systematic and intelligent investigation the faults can usually be located and rectified. Usually when the engine stops, symptoms give a clue to the cause, but where this is not the case, the trouble can be more easily diagnosed by following a definite method of investigation.

The three conditions mentioned above are as follows:—

1. The required quantity of combustible mixture (petrol and air) must enter the engine, which means that a sufficient supply of fuel must be available at the carburetter and that the throttle should open and close freely.
2. There must be a good spark at the plug points, when under compression, and at the correct time in relation to the position of piston on its upward stroke.
3. The engine must be in good mechanical condition, there must be good compression in cylinder and crankcase, and no air leaks at the various joints.

When cause of the trouble is not evident carry out a preliminary examination covering the following points, but if this fails to trace the cause reference should be made to the Fault Finding Charts.

Having made sure that there is "petrol" in the tank, and tap is in the ON position, depress tickler to check if there is any stoppage or obstruction in the fuel supply either in the tap, fuel pipe, banjo union or fuel needle seating. Being satisfied that fuel is reaching the carburetter, next unscrew sparking plug and with high tension lead attached lay on cylinder head. Test by turning engine by means provided, and if the spark is satisfactory it is possible that the timing is incorrect. Finally examine the carburetter controls to make certain the throttle is actually opening when the control lever is moved.

No reference has been made in this booklet to further dismantling beyond that necessary for decarbonising because special equipment is necessary for dealing with the lower half of the engine and to ensure a satisfactory job it is far better to entrust this work to the dealer from whom the complete machine was purchased or to return the engine unit complete to Villiers Service Department.

If for any reason the lower half of the unit has been dismantled, it is **ESSENTIAL** that the clutch spring retaining nut is correctly positioned to give an adequate amount of end float in the clutchshaft, otherwise expensive replacements will soon be necessary in the gearbox. The position of the nut should be such that the effective width of the clutch assembly, i.e., the distance between the outer end of the large splines on the clutch shaft and the outer face of the lockwasher, which it is in **position over** the clutch spring retaining nut, is between 3.665" and 3.680".

FAULT FINDING CHART.

Sequence of Testing.	Possible Trouble.	Remedy.
Engine will not start.		
Depress tickler on carburetter to check whether fuel is reaching carburetter.	No fuel reaching carburetter. Air lock in petrol pipe.	Turn tap to ON, refill tank, clear air vent in filler cap. Turn on reserve tap where fitted.
If no fuel, even when tap is on and fuel is in tank.	Choked petrol pipe, filter on tap, filter in banjo. Fuel needle sticking in seating.	Remove and clean out. Dismantle carburetter and fit new needle.
Test for spark by holding sparking plug body on cylinder head.	Leak along insulation of plug or high tension lead.	Try a new plug of the type recommended and/or new H.T. lead.
If still no spark: Test for spark at end of H.T. lead held $\frac{1}{8}$ " from cylinder fins.	Plug points may be oily or sooted up. If no spark at end of H.T. lead, contact breaker point gap may be too narrow or points pitted or dirty or oily.	Clean plug or fit new one. Adjust point gap to .015 inches. Clean.
	Moisture on insulation of condenser box.	Clean and dry out.
	High tension pickup not making good contact on ignition coil due to corrosion or misplacement.	Clean and correct.
	Cracked insulation of adjustable contact breaker point.	Renew.
	Damaged insulating sleeving on wires connecting contactbreaker to coil or condenser.	Replace with new sleeving.
	Faulty connection to low tension wire of ignition coil.	Correct.
	Faulty Condenser.	Replace.
	Faulty ignition coil.	Replace.

FAULT FINDING CHART—(continued).

Sequence of Testing.	Possible Trouble.	Remedy.
If above tests are satisfactory but engine will not start.	Mixture may be too rich due to use of strangler, or incorrect setting of taper needle.	Open throttle wide and depress kickstarter several times to clear engine of petroil mixture, adjust taper needle, drain crankcase.
	Air leak at carburetter stub or manifold joint. causing weak mixture.	Correct.
	Incorrect ignition timing due to flywheel having slipped on driving shaft taper.	Check, following instructions given for respective type of engine.
Engine four or eight strokes.		
Strangler may not be fully open or taper needle in the "RICH" position. Air filter where fitted may need cleaning. Check by watching for excessive smoke from exhaust pipe or silencer.	Mixture too rich.	Lower taper needle by moving to "WEAK" position. Lower needle by adjuster screw fitted in throttle.
	Engine may four stroke for a little while after standing due to accumulation of oil in crankcase.	Usually ceases when engine has been running for a few minutes unless too much oil has been mixed with the petrol.
	Flooding of carburetter.	Persistent flooding is usually due to dirt under fuel needle seating, or sticking fuel needle, or damaged seating or punctured float.
Engine Lacks Power.		
Engine out of tune, bearings worn. Unsuitable sparking plug. Loss of compression.	Engine out of tune, bearings worn. Unsuitable sparking plug.	Overhaul. Replace with recommended type.
	Loss of compression.	Tighten cylinder head bolts. Replace worn piston rings.
	Incorrect "Petroil" mixture.	Correct mixture is 1 part oil, 20 parts petrol.
Excessive carbon deposit on piston crown and cylinder head.		Decarbonize.

FAULT FINDING CHART—(continued)

Sequence of Testing.	Possible Trouble.	Remedy.
	Exhaust system choked with carbon.	Clean out silencer and exhaust pipes.
	Incorrect carburetter setting.	Check with setting chart.
	Air Cleaner choked.	Wash in petrol, drain and dip in thin oil.
	Obstruction in fuel supply.	Clean out tap, fuel pipe and filters.
	Incorrect ignition timing.	Check against timing chart.
	Brakes binding.	Adjust.
	Driving chains too tight.	Adjust.
Engine will not run Slowly.	Weak mixture due to air leaks at carburetter stub or manifold joint, crankcase and cylinder base joints.	Tighten all joints.
	Crankcase drain screw loose or missing.	Tighten or replace.
	Worn crankshaft bearings or leaking compression gland.	Replace.
	Ignition timing too far advanced.	Correct.
Engine Suddenly Stops Firing.	Sparking plug lead detached.	Replace and tighten nut.
	Plug points bridged by oil, carbon, or deposit caused by use of leaded petrol.	Clean or replace.
	Short circuit of high tension current by water on H.T. lead.	Dry out.

MARK 1.F. UNIT.
ENGINE AND GEARS.

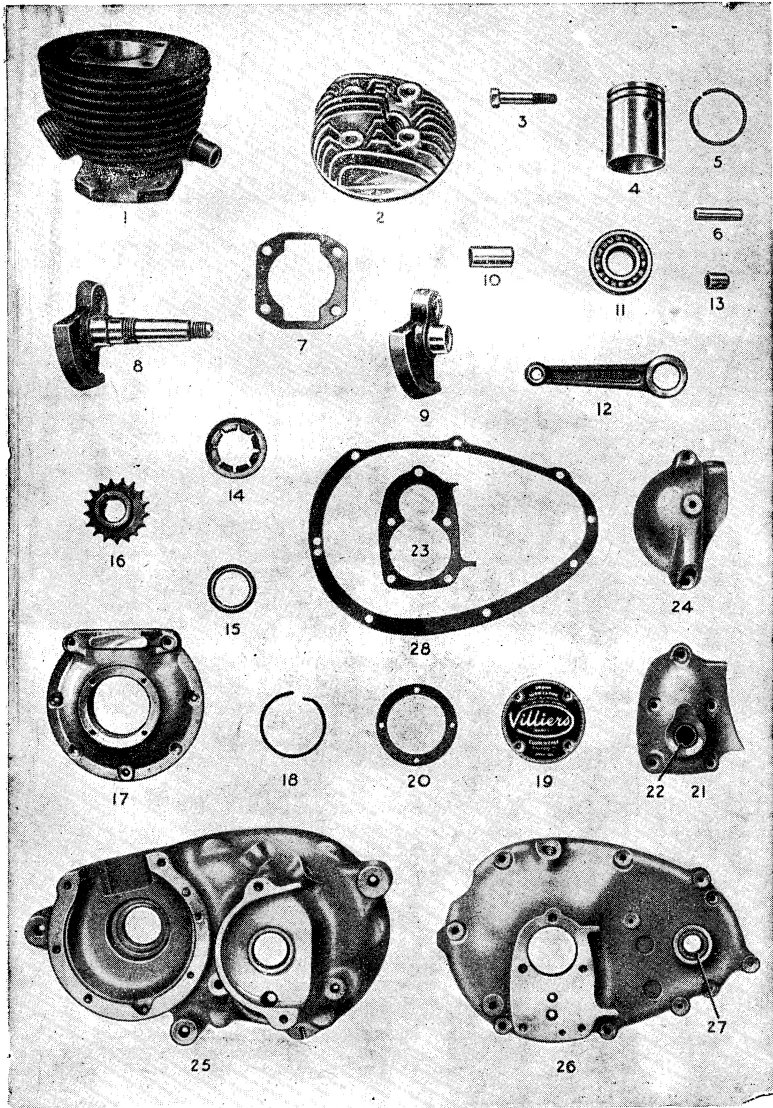

Always quote Engine Number when ordering spares.

MARK 1.F. UNIT.

ENGINE AND GEARS.

<i>Component.</i>	<i>Illus. No.</i>	<i>Part No.</i>	<i>No. per Set.</i>
Cylinder	1	B7261F/1	1
Cylinder Head	2	C8618	1
Cylinder Head Bolt	3	E3907	4
Piston, Bushed, Standard Size	4	C7045	1
Piston Ring, Standard Size	5	E6141	2
" " .015" Oversize	5	E7516	2
" " .03" " " 	5	E7518	2
Gudgeon Pin	6	E7198	1
Joint Washer, Cyl. Base	7	E7168	1
Driving Shaft, Right Hand	8	D7266	1
" " Left " " 	9	D7267	1
Crankpin, .001" Oversize	10	E7493	1
Ballbearing, Driving Shaft	11	6205	2
Con. Rod, .001" Oversize (bushed)	12	D7494	1
" " Small End Bush	13	E6192	1
Crankcase Gland Spring	14	E6221	1
" " Bush	15	E6724/1	1
Engine Sprocket	16	E6725	1
" " Lockwasher	—	E7197	1
Crankcase, Left Hand	17	B7262	1
" " Bearing Circlip	18	E7189	1
" " End Plate	19	E7275/2	1
" " End Plate Washer	20	E7276	1
*Kickstarter Cover	21	C7705	1
" " " Bush	22	E7217	1
* " " " Joint Washer... ..	23	E7707	1
*Clutchbridge	24	C7264/1	1
Gearcase	25	A7259	1
*Clutch Case	26	A7711	1
" " Bush	27	E7385	1
" " " Kickstart	—	E7706	1
" " " Joint Washer	28	C7170	1
Exhaust Pipe Nut	—	E3934	1
" " " Washer	—	E4453	1
Clutch Sprocket, Complete	1	D5232	1
" " Cork, Small	2	E5220	5
" " " Large	3	E4960	25
" " Sprocket Balls	—	1" dia.	33
" " " Side Plate	4	E4955	2
" " " " Rivet	5	E5001	5
" " " " Ball Race	—	E4948	1

* See Note on Page 30.

MARK 1.F. UNIT.
ENGINE AND GEARS—Contd.

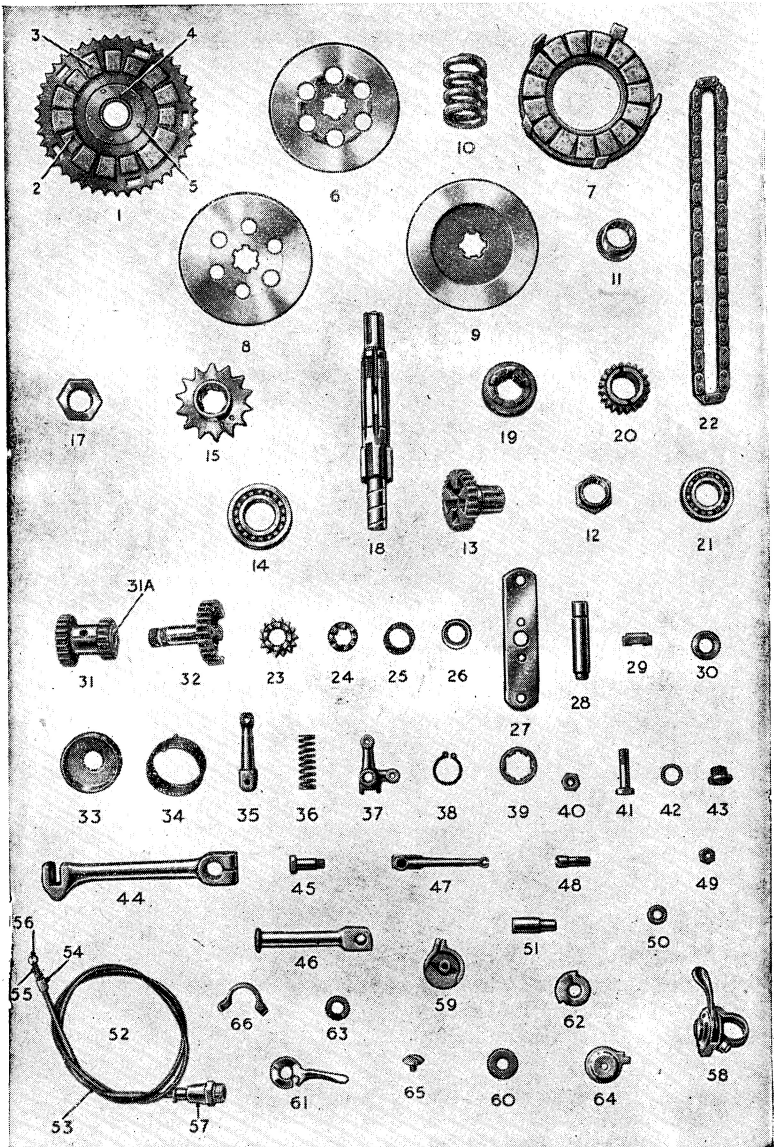

Always quote Engine Number when ordering spares.

MARK 1.F. UNIT.

ENGINE AND GEARS—*Conva.*

<i>Component.</i>	<i>Illus. No.</i>	<i>Part No.</i>	<i>No. per Set.</i>
Clutch Plate, Centre, Dished ...	6	D4954	1
„ „ Corked ...	7	D5233	1
Clutch Plate ...	8	D4951	1
„ „ Outer ...	9	D5433	1
„ Spring ...	10	E5558/1	1
„ „ Bush ...	11	E5556	1
„ „ Nut ...	12	E7073	1
High Gear Wheel ...	13	E7056	1
„ „ Ball Bearing, 25 × 52 × 9	14	6005	1
„ „ Driving Sprocket ...	15	E7074	1
„ „ „ „ Locknut	17	E6930	2
Lock Screw for Sprocket Locknut	—	E5561	1
Clutchshaft ...	18	C7215	1
Sliding Dog Clutch ...	19	E7059	1
Low Gear Wheel, 20 Teeth ...	20	E7057/1	1
Ball Bearing, Clutchshaft, 20 × 42 × 9	21	6004	1
Primary Chain, 56 Pitches ...	22	110037	1
Kickstarter Pinion ...	23	E7219	1
„ Ratchet ...	24	E7220/1	1
„ Ratchet Spring ...	25	E7223/1	1
K.S. Spring Retaining Washer ...	26	E7221/1	1
Countershaft Bridge ...	27	E7269	1
„ Spindle ...	28	E7060/1	1
Clutch Cotter ...	29	E7270/1	1
Countershaft Washer ...	30	E7063	1
„ Bushed ...	31	E7058/1	1
„ Bush ...	31A	E7061/1	2
* Kickstarter Shaft ...	32	D7704	1
Lockwasher, Clutch Spring Nut...	—	E7609	1
Kickstarter Spring Cap ...	33	E7232	1
„ Spring ...	34	E7224	1
Forked Joint for Selector ...	35	E7067	1
Gear Change Spring ...	36	E7092	1
„ Selector Lever ...	37	E7194	1
Circlip, Clutchshaft ...	38	E7454	1
Splined Washer, Brass ...	39	E7072	1
Nut, K.Start and Bridge Bolt ...	40	E4252	3
Bolt, K.Start and Bridge ...	41	E4251	3
Washer, Oil Filler Plug ...	42	V107 × 3	1
Oil Filler Plug ...	43	E4104/1	1

* See Note on Page 30.

MARK 1.F. UNIT.

ENGINE AND GEARS—Contd.

<i>Component.</i>	<i>Illus. No.</i>	<i>Part No.</i>	<i>No. per Set.</i>
Kickstart Lever	44	D7246	1
" Pedal Pivot Pin	45	E4098	1
" Pedal	46	E4096	1
Clutch Lever	47	D6546	1
Kickstarter Stop Pin	48	E7222	1
" " " Nut	50	E1050	1
" " " Washer	49	E3961	1
Spindle, Gear Selector Lever	51	E7071/1	1
Gear Control Cable with Fittings	52	E7381	1
Outer Cable with Ferrules	53	E7492	1
Inner Cable with Nipple E7199	—	E7491	1
Cable Adjuster	54	V105 × 1	1
" " Locknut	55	V105 × 2	1
" Nipple, Lever End	56	E7404	1
" " Gearbox End	—	E7199	1
Guide for Fork Joint	57	E7068	1
Gear Control Lever Assy. (59-66)	58	E7456	1
" " Body	59	V142 × 1	1
" " Fibre Washer	60	V142 × 10	2
" " Lever	61	E7200	1
" " Friction Plate	62	V142 × 9	1
" " Spring Washer	63	V142 × 11	1
" " Top Plate	64	E7211	1
" " Top Screw	65	V117 × 5	1
" " Body Clip	66	V142 × 7	1
Screw, K.Start Cover $1\frac{11}{16}$ " × 90°	1	E7129	5
" Crankcase $1\frac{5}{16}$ " × 90°	2	E7271	2
" Clutchbridge $1\frac{13}{16}$ " × 60°	3	E4934	1
" Crankcase $1\frac{3}{4}$ " × 90°	4	E7128	4
" Clutch Cover 1" × 90°	4	E7326	2
Circlip, Clutchshaft K.S. End	5	E6552	1
Clutch Cover Bolt & Drain Screw	6	E3222	5
Plain Washer for Bolt, $\frac{1}{4}$ "	7	E2924	7
Drain Screw, Crankcase	8	E1962	1
Fibre Washer for Drain Screw	9	E1905	1
Nut Cylinder Base Stud	—	E3961	4
Circlip, Gudgeon Pin	10	E5218	2
Spring Washer, $\frac{5}{16}$ "	11	E1050	6
Clutch Push Rod, Long	12	E7196	1
" " Short	13	E4945	1
Key, Engine Sprocket	14	E5124	1
Screw, Crankcase End Plate	15	E7530	4

MARK 1.F. UNIT.
ENGINE AND GEARS—*Contd.*

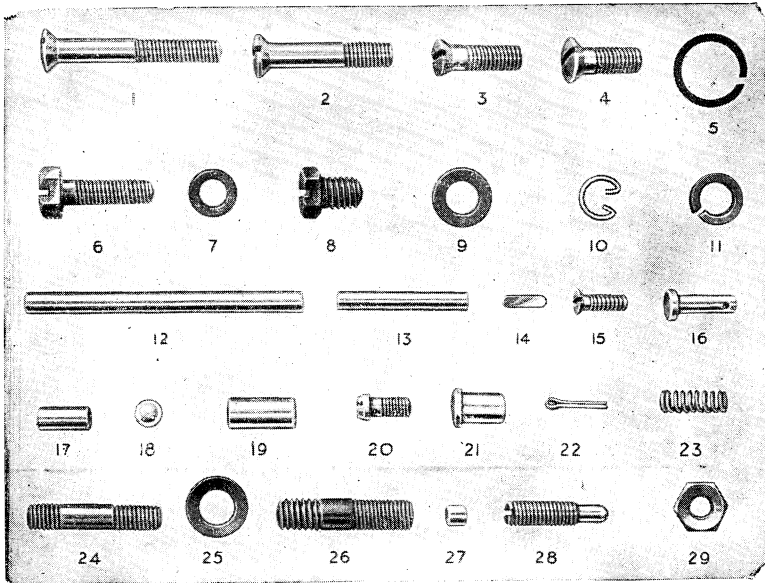

<i>Component.</i>	<i>Illus. No.</i>	<i>Part No.</i>	<i>No. per Set.</i>
Pivot Pin, Forked Joint ...	16	E7070	1
Dowel, Crankcase, $\frac{3}{16}$ " dia. ...	17	E2677	1
.. Clutchcase, $\frac{1}{4}$ " ,, ...	17	E7619	2
Ball K.Start Pedal ...	18	E9776	1
Stop Pin, Selector Lever, $\frac{5}{16}$ " dia. ...	19	E7066	1
Clip Screw, Gear Control ...	20	V142 x 5	2
Split Pin, Pivot Pin ...	22	E421	1
Spring, K.Start Pedal ...	23	E4270	1
Stud, Clutch Cover, $\frac{1}{4}$ " x $1\frac{5}{16}$ " ...	24	E5107	2
Washer, Cyl. Head Bolt ...	25	E5808	4
Stud, Cylinder Base ...	26	E363	4
Crankpin Roller ...	27	E9777	28
Adjuster Screw, Clutch Lever ...	28	E6567	1
Locknut for Screw ...	29	E7765	1
Peg, Gear Operating Lever ...	—	E7195	1

Always quote Engine Number when ordering spares.

MARK 1.F. UNIT.

MAGNETO.

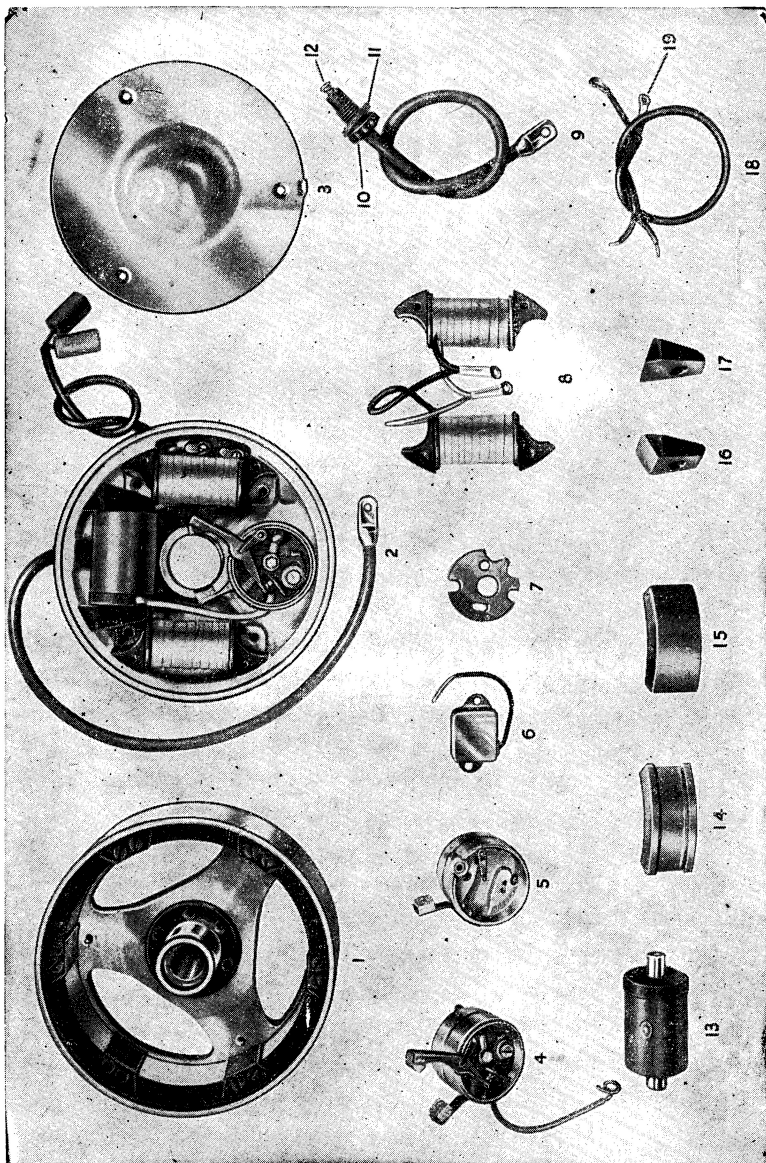

Always quote Engine Number when ordering spares.

MARK 1.F. UNIT.

MAGNETO.

<i>Component.</i>	<i>Illus. No.</i>	<i>Part No.</i>	<i>No. per Set.</i>
Flywheel Assembly, Less Cover...	1	R110	1
Armature Plate Assembly ...	2	A109	1
Flywheel Cover	3	M1580	1
Condenser Box Assembly ...	4	M1864	1
Con. Box only, with Oil Pad ...	5	M1872	1
Condenser	6	M1750	1
Insulating Pad, Con. Box ...	7	M1803	1
Lighting Coils, Assembly ...	8	M1963	1 pair
High Tension Lead Complete ...	9	1148 × 4	1
„ „ Terminal	10	1124 × 8	1
„ „ Terminal Felt Washer	11	E869	1
„ „ Spring	—	1010 × 11	1
„ „ Spring Pad	12	1046 × 13	1
„ „ Spring Screw	—	M2703E	1
„ „ Coil	13	M1361	1
Dummy Magnet	14	M1553	2
Magnet, Red and White	15	M1354	4
H.T. Coil End, L. Hand	16	M1855	1

Always quote Engine Number when ordering spares.

MARK 1.F. UNIT.

MAGNETO—*Contd.*

<i>Component.</i>	<i>Illus. No.</i>	<i>Part No.</i>	<i>No. per Set.</i>
H.T. Coil End, R. Hand ...	17	M1856	1
Twin Lighting Lead ...	18	M1405	1
Terminal End ...	19	M1291	2
Point Bracket ...	1	M1873	1
Fibre Washer, Locking Screw ...	2	M1805	1
Brass Washer, ,, ,, ...	3	M1802	1
Locking Screw, Point Bracket ...	4	M1801	1
Contact Screw, ,, ,, ...	5	1006 × 3	1
,, ,, Washer ...	6	1113 × 5	3
Rocker Arm with Point and Pad...	7	M1714	1
Stud, Con. Box Fixing ...	8	1053 × 1	2
Washer for Stud ...	9	1002 × 13	2
Nut for Stud ...	10	1002 × 15	2
Screw, Flywheel Cover ...	11	M1228	3
Spring, Rocker Arm ...	12	1047 × 3	1
Top Plate, Pole Shoe ...	13	M1822	6
Armature Plate Fixing Screw ...	14	1124 × 9	4
Pole Shoe Fixing Screw ...	15	1002 × 9	12
Insulating Washer ...	16	M1916	1
Terminal Screw ...	17	M1670	2

MARK 1.F. UNIT.

MAGNETO—*Contd.*

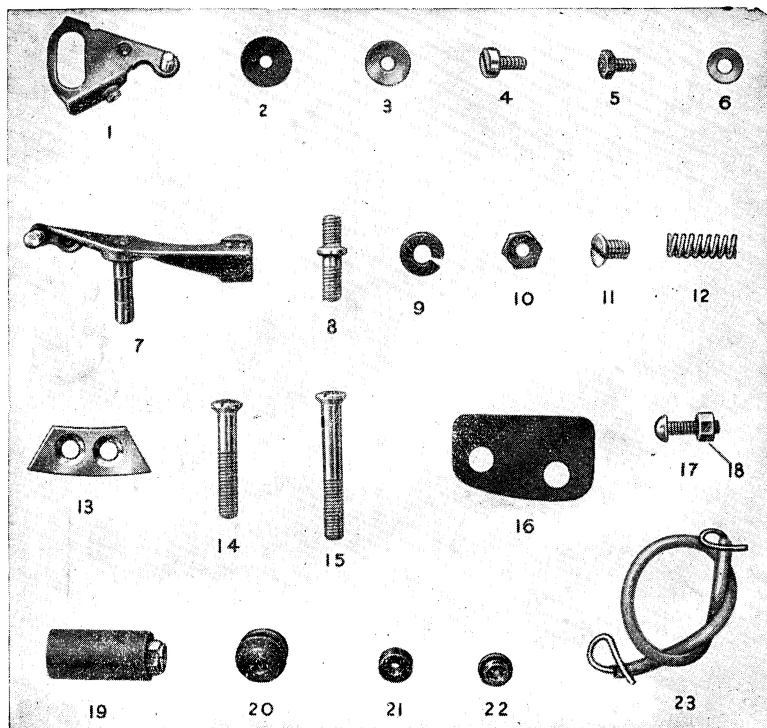

<i>Component.</i>	<i>Illus. No.</i>	<i>Part No.</i>	<i>No. per Set.</i>
Nut for Screw	18	1113 × 4	2
Lighting Lead Connector ...	19	1106 × 14	2
Rubber Grommet	20	M1232	1
Terminal Bush, Inside	21	1013 × 13	2
,, ,, Outside	22	1013 × 12	2
L. T. Lead, H. T. Coil to Point Bracket	23	482	1

See page 34 for details of latest contact breaker assembly.

MARK 1.F. UNIT.
CARBURETTER.

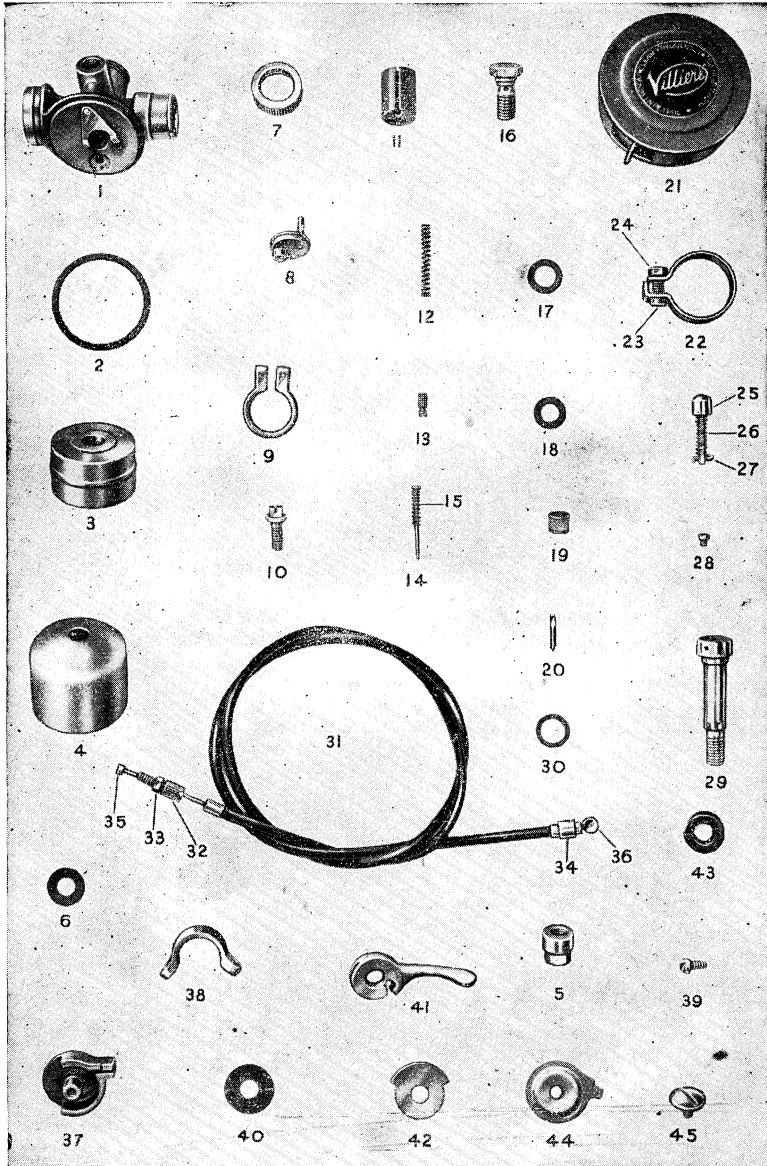

Always quote Engine Number when ordering spares.

MARK 1.F. UNIT.

CARBURETTER.

<i>Component.</i>	<i>Illus. No.</i>	<i>Part No.</i>	<i>No. per Set.</i>
Body with Fuel Bush, Needle Lever	1	V649	1
Joint Washer, Float Cup ...	2	V107 × 2	1
Float	3	V107 × 1	1
„ Cup	4	V146 × 6	1
Bottom Nut	5	V581	1
„ Washer	6	V107 × 4	1
Top Ring	7	V367	1
Top Disc with Guide Peg ...	8	V368	1
Body Clip	9	V326	1
„ „ Screw	10	V754E	1
Throttle	11	V365	1
„ Spring	12	V369	1
Adjuster, Taper Needle	13	V413	1
Taper Needle, No. 2½	14	V651	1
„ „ Spring	15	V107 × 7	1
Banjo Union Bolt	16	V382	1
Banjo Washer, Large Hole ...	17	H104 × 8	1
Banjo Washer, Small Hole ...	18	V383	1
„ Gauze	19	V404	1
Fuel Needle	20	V355	1
Air Filter with Clip	21	EM653	1
„ „ Clip	22	EM618	1
„ „ Clip Bolt	23	E5102	1
„ „ Clip Bolt Nut	24	1002 × 15	1

MARK 1.F. UNIT.

CARBURETTER—*Contd.*

<i>Component.</i>	<i>Illus. No.</i>	<i>Part No.</i>	<i>No. per Set.</i>
Tickler	25	V207	1
" Spring	26	V369	1
" Split Pin	27	V111 × 2	1
Centrepiece Locating Screw	28	V424	1
Centrepiece with Jet	29	Quote Eng. No. 1	
" Fibre Washer	30	V107 × 3	1
Control Cable Assembly	31	V667	1
" " Adjuster	32	V105 × 1	1
" " " Locknut... ..	33	V105 × 2	1
" " Sleeve	34	V108 × 4	1
" " Nipple, Carb. End	35	V145 × 16	1
" " Nipple, Control End	36	V123 × 15	1
" Body	37	V405	1
" " Clip	38	V142 × 7	1
" " " Screw	39	V142 × 5	2
" " Fibre Washer	40	V142 × 10	2
" Lever	41	V406	1
" " Friction Plate	42	V429	1
" " Spring Washer	43	V142 × 11	1
" " Top Cover	44	V387	1
" " Top Cover Screw... ..	45	V117 × 5	1
Carburetter Complete with Control and Filter		— Quote Eng. No. -	

MODIFICATIONS — SPECIAL NOTE.

The part numbers for certain components listed on pages 15—16 only apply to engines bearing serial number 11,167 up. This is because of a change in design to the clutchcase, kickstarter shaft and housing on later engines, and the parts at present used are not interchangeable, except as a complete set, with the original parts. The table below shows the part numbers to be quoted on spares orders.

<i>Component</i>	<i>Part Numbers for Engines up to No. 11,167</i>	<i>Part Numbers for Engines No. 11,167 up</i>
Clutchcase	A7260	A7711
Kickstarter End Cover	C7213	C7705
Kickstarter Shaft	D7216	D7704
Kickstarter Shaft Bush	Not fitted	E7706
Joint Washer	E7245	E7707

MARK 1.F. UNIT.
LIGHTING SET.

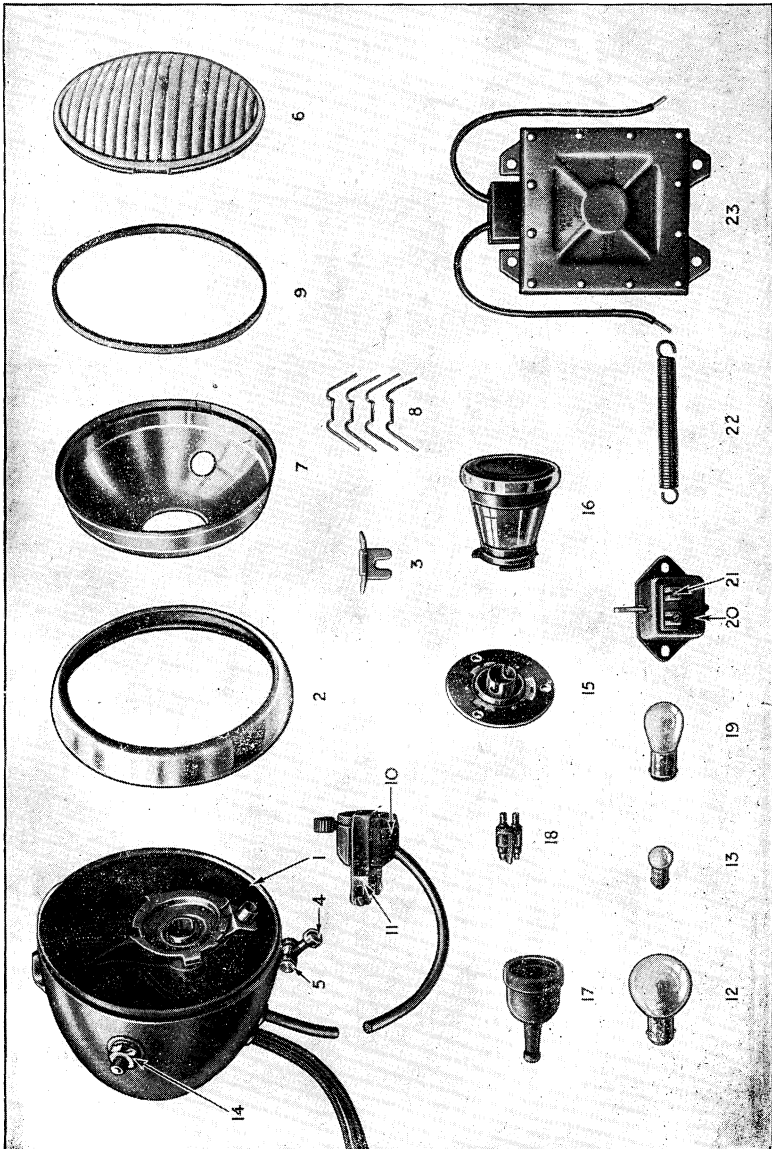

Always quote Engine Number when ordering spares.

MARK 1.F. UNIT.

LIGHTING SET TYPE "A."

HEAD LAMP.

	<i>Illus. No.</i>	<i>Part No.</i>
Lamp complete with Cables, Bulbs, Dip Switch	—	BH1302
Lamp Body with Switch, Cables and Bulb Holders	1	SA1302/36
Back Shell Assembly complete with Cable	—	1302-44
Rim Assembly with Reflector, Clips, Glass, Cork Ring	—	1302/31
Rim only with Four Reflector Springs ...	2	1302/43
Clip for Rim	3	800/58B
Screw for Rim	4	890-24A
Nut for Screw	5	930-12
Front Glass	6	1302-2
Reflector	7	1302-3
Reflector Retaining Wire Clip	8	897-1
Cork Ring	9	1302-6
Holder, Main Bulb	—	930-33C
Clip and Screw, Bulb Holder	—	1185-57
Dip Switch, No. 99	10	380521
Clip and Screw Assembly for Dip Switch	11	380520
Main Bulb 6-Volt—12/12 Watt ...	12	
Pilot Bulb 6-Volt—3 Watt, Single Contact	13	
Spindle Assembly, Light Switch ...	—	1302-45
Switch Lever complete with Spindle and Split Pin	—	SA1302-46
Contact, Light Switch	—	608033
Spring, Light Switch	—	608030
Nut, Lamp Fixing	14	182511
Washer for Nut	—	S85-10

TAIL LAMP TYPE 477.

Lamp complete with Bulb and Rubber Cover	—	53122A
Base with Bulb Holder	15	526293
Body with Ruby Glass and Celluloid Window	16	526295

MARK 1.F. UNIT.

Tail Lamp Type 477—Contd.	<i>Illus. No.</i>	<i>Part No.</i>
Rubber Cover	17	526286
Adaptor	18	552101
Bulb, Double Filament		
6-Volt—3 Watt Tail		
6-Volt—18 Watt Stop Light ...	19	190
STOP LIGHT SWITCH.		
Switch Complete	20	31281
Contact Grub Screw	21	120514
Pull Spring	22	315543
RECTIFIER.		
Westalite Rectifier	23	2L985

VILLIERS ENGINE SERVICE.

When, after a considerable mileage, a complete major overhaul of the engine unit becomes necessary, we will accept the old engine regardless of condition providing that it is complete with magneto and carburetter to our catalogue specification and supply a fully reconditioned engine in part exchange. The reconditioned unit carries the same six months guarantee as a new unit.

REBORES.

We can re bore your existing cylinder and supplying a suitable oversize piston, providing the cylinder will clean up to our usual oversize of either .015" O/S or .030" O/S.

CRANKSHAFT RECONDITIONING.

When big end replacement is necessary we will supply a reconditioned crankshaft assembly in part exchange for the original assembly.

RE-CORKING CLUTCH.

We can carry out the following on an exchange basis:—

- Re-Cork Clutch Sprocket.
- Re-Cork Clutch Plate.
- Re-Centre Clutch Sprocket.

Prices for above exchanges available on application.

CONTACT BREAKER ASSEMBLY (latest pattern).

The contact breaker assembly illustrated below supersedes that shown on page 25. The cam adjuster has been introduced to facilitate accurate setting of the contact points.

ADJUSTMENT.

Turn flywheel clockwise till rocker pad "E" is on top of the cam profile of the flywheel boss. Release screw "A". Position bracket "B" by turning adjuster cam "C" until .015" feeler gauge can be inserted between the contact points. Tighten Screw "A" and withdraw feeler gauge. It is not necessary to disturb nut "D" when adjusting point gap. A felt pad "F" is used to keep the cam lightly lubricated. It is advisable to occasionally re-impregnate the pad with molten high melting point grease.

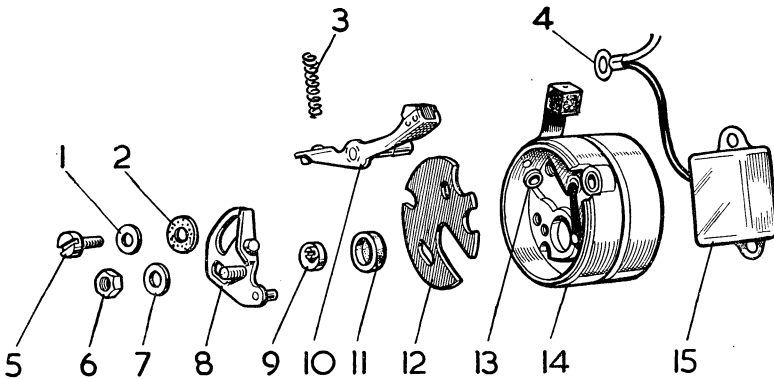
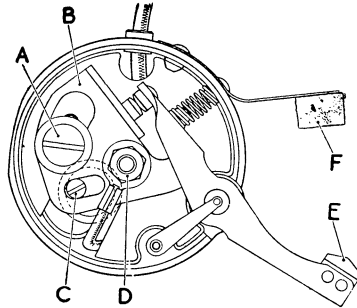

SPARE PARTS LIST.

Illus. No.	Part No.	Description.	Qty.	Price Each.		
				£	s.	d.
1	M.1802E	Washer, Point Bracket Lockscrew	1			1
2	M.1805E	Insulating Washer, Point Bracket Lockscrew	1			1
3	1047 × 3E	Spring, Rocker Arm	1			2
4	M.1291E	Shoe, L.T. Lead	2			1
5	M.1801E	Point Bracket Lockscrew	1			2

SPARE PARTS LIST—contd.

<i>Illus. No.</i>	<i>Part No.</i>	<i>Description.</i>	<i>Qty.</i>	<i>Price Each.</i>		
				£	s.	d.
6	1113 × 4E	Nut, Cut-out Terminal and Point Bracket	4			2
7	1113 × 5E	Washer, Brass	4			1
8	M.2313E	Point Bracket	1	2		3
9	M.2311E	Point Bracket Cam	1			6
10	M.1714E	Rocker Arm	1	4		0
11	M.2310E	Bush for Cam	1			6
12	M.2309E	Insulating Plate	1			4
13	1010 × 16E	Insulating Bush	3			2
14	M.2506	Condenser Box only	1	4		6
15	M.1750D	Condenser	1	4		9
—	M.2504	Condenser Box Assembly complete	1	18		6

ESTIMATES.

If required, we are always prepared to give an estimate before proceeding with any repair. This entails a certain amount of labour in dismantling to ascertain what new parts will be required, and therefore, in the case of any estimate not being accepted for special reasons, a small charge is made for our mechanics' time in taking down the parts for report.

Estimates must be treated as approximate only. We reserve the right to include additional parts should these be found, on further examination or on bench test, to be necessary, to make the repair satisfactory.

We do not undertake to fit to engines sent to us for overhaul, any parts specified by the customer when we consider that other parts are necessary to make an efficient repair. In such cases, we are prepared to supply the customers' requirements in spares, but we do not undertake to fit them.

TERMS OF BUSINESS.

Unless ledger account facilities are already in existence, repairs and spares must always be treated on a cash basis. New ledger accounts will be opened for items of £10 (ten pounds) and upwards for approved accounts.

An extra amount must always be included in remittances to cover the cost of postage or carriage and packing on spare parts. This is 5% extra up to £10 value. Minimum extra is 1/-. Stamps cannot be accepted for items over 1/- (one shilling) in value.

Any engine or sub-assembly sent to our Works for repair and not paid for within 12 months from the date of our estimate or from the date of notification of completion of repair, will be dealt with under the Disposal of Uncollected Goods Act, 1952.

When making remittances by telegraph money order, the name and address of the sender must be included in the space provided on the Post Office Requisition Form for a private message from remitter to payee. Unless this is done, the Post Office does not give this information upon the telegram.

GUARANTEE.

WE give the following guarantee with VILLIERS Engines and Accessories in place of any implied guarantee by statute or otherwise, all such guarantees being in all cases excluded. No statement or representation contained in this catalogue shall be construed as enlarging or varying this guarantee. In the case of engines and accessories which have been used for " hiring out " purposes, or from which our trade mark, name, or manufacturing number has been removed, no guarantee of any kind is given or is to be implied.

We guarantee, subject to the conditions mentioned below, that all precautions which are usual and reasonable have been taken by us to secure excellence of materials and workmanship, but this guarantee is to extend and to be in force for six months only from the date the engines or accessories are despatched by us, and the damages for which we make ourselves responsible under this guarantee are limited to the replacement of a part manufactured by us which may have proved defective. We cannot accept responsibility for the replacement of any proprietary articles or parts not manufactured by us, unless the makers of these parts agree to replacement.

We do not undertake to refit or bear the cost of replacement or refitting such new part. We guarantee, subject to the conditions mentioned below, to make good at any time within six months any defects in these respects. As VILLIERS Engines and Accessories are liable to derangement by neglect or misuse, this guarantee does not apply to defects caused by wear and tear, misuse and neglect.

CONDITIONS OF GUARANTEE.

If a defective part should be found in our engines or accessories, it must be sent to us carriage paid and accompanied by an intimation from the sender that he desires to have it repaired free of charge, under our guarantee, and he must also furnish us at the same time with the number of the engine, and full particulars of purchase. Failing compliance with the above, no notice will be taken of anything that may arrive, but such articles will lie here at the risk of the sender, and this guarantee or any implied guarantee shall not be enforceable.

THE TERM " AGENT " is used in a complimentary sense only, and those firms whom we style our agents are not authorised to advertise, incur any debts, or transact any business whatsoever on our account other than the sale of goods which they may purchase from us, nor are they authorised to give any warranty or make any representations on our behalf or sell subject to or with any conditions other than those contained in the above guarantee.

The guarantee becomes void if any parts not made or supplied by **THE VILLIERS ENGINEERING COMPANY, LTD.**, are fitted to a **VILLIERS** engine. To safeguard his own interests, the owner should always insist upon genuine **VILLIERS** parts.

Villiers

*The Power and the Heart
of a fine machine*